

PANZITTA SALES & SERVICE
72 George Avenue
Wilkes-Barre, PA 18705
570-822-6720 800-822-6720
www.panzittasales.com

WHEELTRONIC  **LTD.**

**ADJUSTABLE
AIR-HYDRAULIC
SLIDING JACKBEAM
6000 lbs.**

“EPIC” SERIES

INSTALLATION AND OPERATION MANUAL

JACKING BEAM ASSEMBLY 6000 LBS.

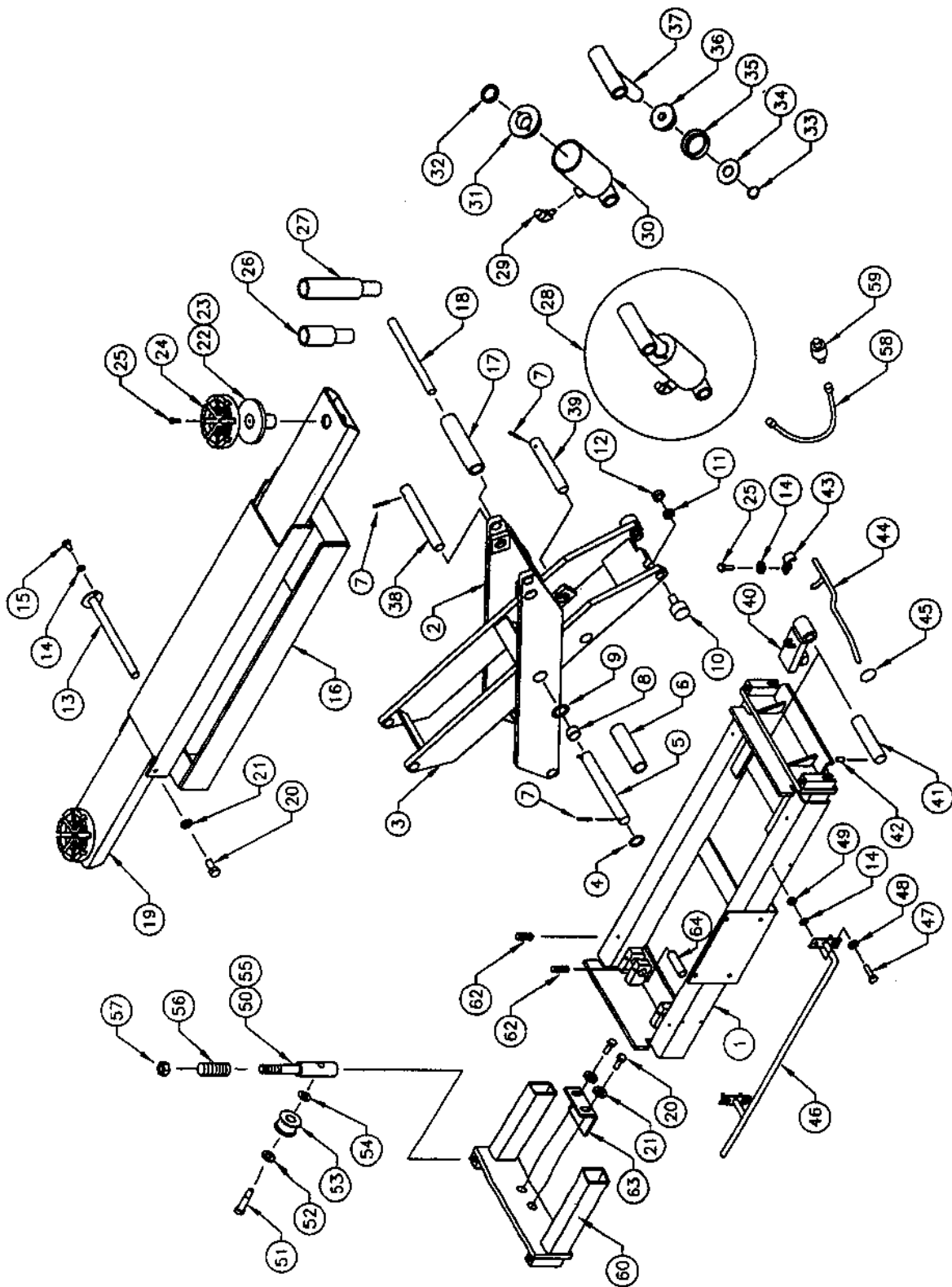

ITEM	QTY.	DESCRIPTION	PART #
1	1	BASE FRAME WELDMENT	3-0842
2	1	OUTER SCISSOR WELDMENT	3-0824
3	1	INNER SCISSOR WELDMENT	3-0825
4	1	WASHER, 1 1/32" ID	6-0807
5	1	SCISSOR CENTER SHAFT	1-2270
6	1	CENTER PIPE SPACER	1-0575
7	4	SPRING PI, 3/16" X 2" LG	6-0146
8	4	BUSHING	6-2230
9	2	THRUST WASHER	6-0328
10	2	CAM FOLLOWER	1-1269
11	2	SPACER	1-0228
12	2	JAM NUT, 5/8"-NF	6-0040
13	2	UPPER SCISSOR PIN	2-1586
14	8	LOCKWASHER, 1/4" ID	6-0056
15	2	HEX HD BOLT, 1/4"-NC X 1/2" LG	6-0554
16	1	TOP WELDMENT	3-0725
17	1	ROLLER ASSEMBLY	1-1997
18	1	ROLLER SHAFT	1-1998
19	2	LIFTING ARM WELDMENT	2-1572
20	6	HEX HD BOLT, 3/8"-NC X 3/4" LG	6-0030
21	6	LOCKWASHER, 3/8" ID	6-0058
22	2	STACK PAD ASSEMBLY COMPLETE	1-2045
23	2	STACK PAD WELDMENT	1-2030
24	2	RUBBER PAD	6-2050
25	4	HEX HD BOLT, 1/4"-NC X 3/4" LG	6-0178
26	2	STACK PAD ADAPTER, 3"	1-1993
27	2	STACK PAD ADAPTER, 6"	2-1580
28	1	CYLINDER ASSEMBLY COMPLETE	3-0474
29	1	VELOCITY FUSE	1-1767
30	1	CYLINDER TUBE WELDMENT	2-0911
31	1	GLAND	1-1152
32	1	ROD WIPER	6-0653
33	1	SNAP RING	6-0581
34	1	KEEPER WASHER	1-1148
35	1	SEAL AND WEAR RING	6-1166
36	1	PISTON	1-1150
37	1	PISTON ROD WELDMENT	2-0913
38	1	OUTSIDE CYLINDER SHAFT	1-1158
39	1	INSIDE CYLINDER SHAFT	1-1163
40	1	SAFETY STOP WELDMENT	2-1577
41	1	SAFETY PIN	1-0561
42	2	SET SCREW, 1/4"-NC X 3/4" LG	6-0438
43	2	CLIP	6-0671
44	1	SAFETY LEVER ARM	1-2271
45	1	KNOB	6-0251

PANZITTA SALES & SERVICE
72 George Avenue
Wilkes-Barre, PA 18705
570-822-6720 800-822-6720
www.panzittasales.com

ITEM	QTY.	DESCRIPTION	PART #
46	1	GUARD RAIL	2-1585
47	4	HEX HD BOLT, 1/4"-NC X 1" LG	6-0008
48	4	FLAT WASHER, 1/4" ID	6-0060
49	4	HEX NUT, 1/4"-NC	6-0032
50	4	ROLLER ASSEMBLY COMPLETE	2-0259
51	4	SHOULDER BOLT, 3/8"-NC X 1" LG	6-0206
52	4	THRUST WASHER, 3/8" ID	6-0223
53	4	TRACK ROLLER ASSEMBLY	2-0098
54	4	THRUST WASHER, 3/8" ID	6-0224
55	4	SPRING STEM	1-0204
56	4	SPRING	6-0081
57	4	NYLON LOCKNUT, 3/8"-NC	6-0042
58	1	HYDRAULIC HOSE	1-0765
59	1	ADAPTER, 3/8"NPT-M x 3/8"JIC-M	6-0011
60	2	ROLLER ADAPTER	3-0841
62	6	SET SCREW 1/4"-20UNC x 1/2" LG	6-0438
63	2	KEEPER BRACKET	1-2381
64	2	LOWER SCISSOR PIN	1-2361
NOTE	1	AIR/HYDRAULIC PUMP COMPLETE	6-1428
NOTE	1	SCISSOR ASSEMBLY COMPLETE	3-0826

- **THE FOLLOWING PARTS ARE FOR (-L) MODELS, REAR, LEFT SIDE AIR CONNECTION**

QTY.	DESCRIPTION	PART #
1	STREET TEE	6-0015
2	1/4"NPT TO 3/8" PLOYTUBE	6-0710
1	1/2" TUBE CLAMP	6-0536
1	90° ELBOW, 1/4"NPT F TO 1/4" NPT F	6-0967

AIR/HYDRAULIC PUMP PARTS LIST

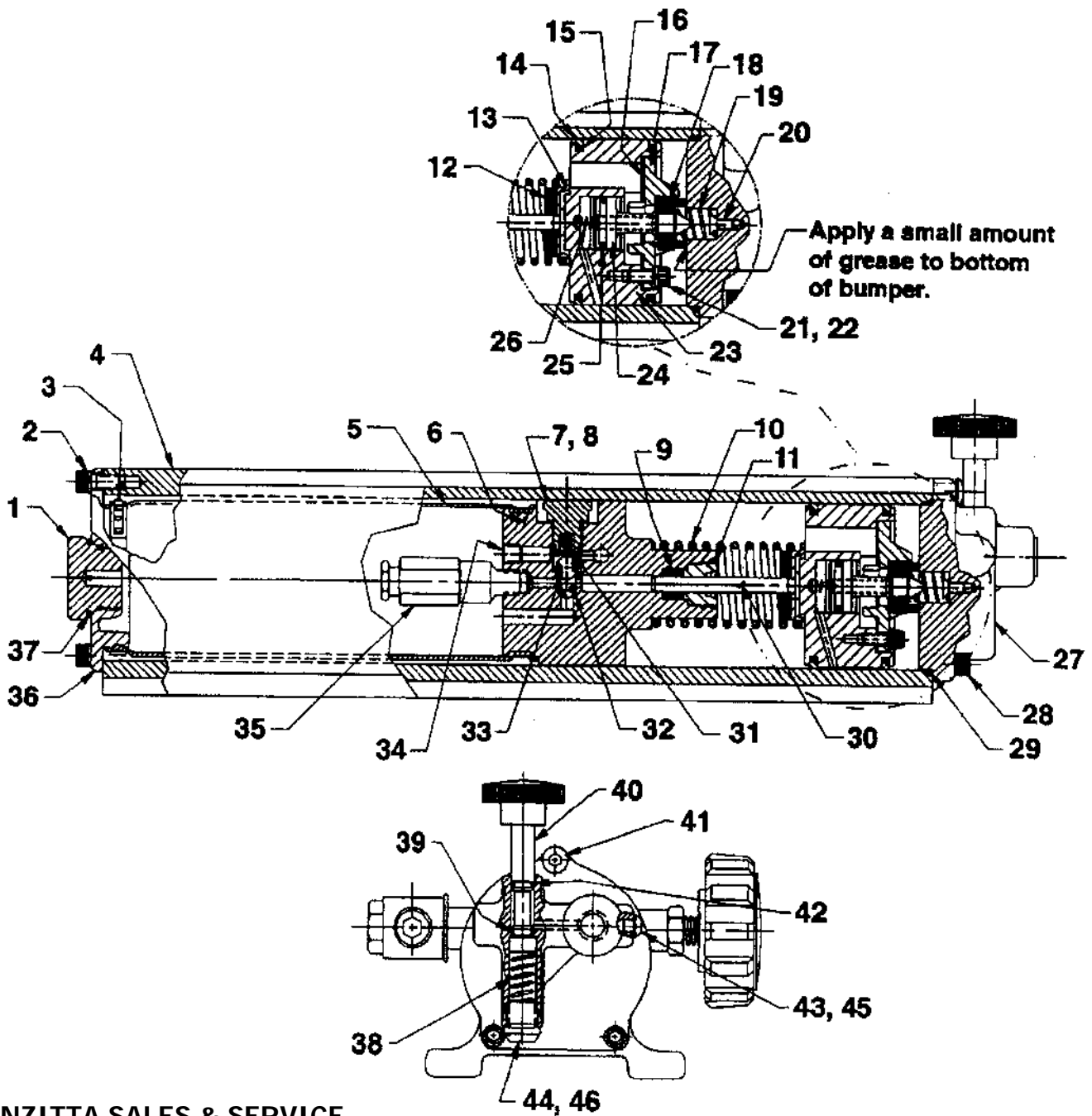

PANZITTA SALES & SERVICE
 72 George Avenue
 Wilkes-Barre, PA 18705
 570-822-6720 800-822-6720
www.panzittasales.com

ITEM	QTY.	DESCRIPTION	PART #
1	1	FILLER PLUG	6-2332
2	3	SCREW, ¼"-NC X ½"	6-2333
3	2	CLAMP	6-2334*
4	1	PUMP HOUSING	6-2335
5	0.5	BLADDER	6-2336*
6	1	PUMP BODY	6-2337
7	1	VALVE SCREW	6-2338
8	1	COPPER WASHER	6-2339*
9	1	U-CUP	6-2340*
10	1	COMPRESSION SPRING	6-2341
11	1	RETAINER	6-2342*
12	1	BUMPER	6-2343*
13	1	SPRING GUIDE	6-2344
14	2	PISTON RING	6-2345*
15	2	O-RING	6-2346*
16	1	GASKET	6-2347*
17	1	PISTON END CASTING	6-2348
18	1	PISTON POPPET	6-2349*
19	1	COMPRESSION SPRING	6-2350*
20	1	FLAT HD SCREW, 8-32 X 3/8"	6-2351
21	3	SOC. HD SCREW, 10-32 X ½"	6-2352
22	3	LOCKWASHER	6-2353*
23	1	PISTON BODY	6-2354
24	1	EXHAUST VALVE SYSTEM	6-2355
25	1	O-RING	6-2356*
26	1	COMPRESSION SPRING	6-2357*
27	1	REAR HEAD	6-2358
28	2	SCREW	6-2359
29	1	O-RING	6-2360*
30	1	PISTON	6-2361
31	1	COMPRESSION SPRING	6-2362*
32	1	STEEL BALL, ¼"	6-2363*
33	1	STEEL BALL, 3/8"	6-2364*
34	1	PLUG FITTING	6-2365
35	1	RELIEF VALVE	6-2366
36	1	END FILLER CAP	6-2367
37	1	O-RING	6-2368*
38	1	COMPRESSION SPRING	6-2369
39	1	O-RING	6-2370*
40	1	VALVE STEM	6-2371
41	1	SCREW, ¼"-NC X ¼"	6-2372
42	1	O-RING	6-2373*
43	1	BUTTON HD SCREW, 10-24 X ½"	6-2374
44	1	SCREW, ½"-NC X ½"	6-2375
45	1	SPECIAL WASHER	6-2376
46	1	O-RING	6-2377
	NOTE:	PART NUMBERS MARKED WITH AN ASTERIX (*) ARE CONTAINED IN REPAIR KIT NUMBER 6-2404	

AIR/HYDRAULIC PUMP PARTS LIST

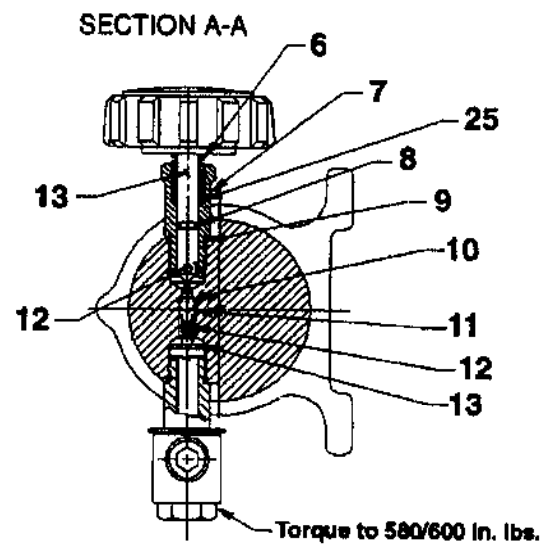
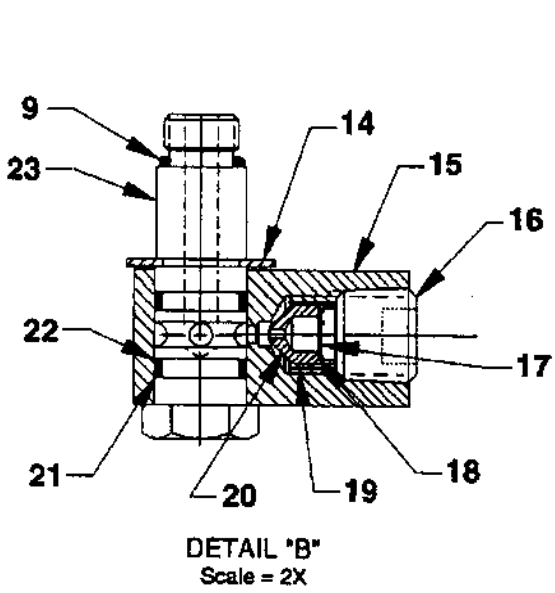
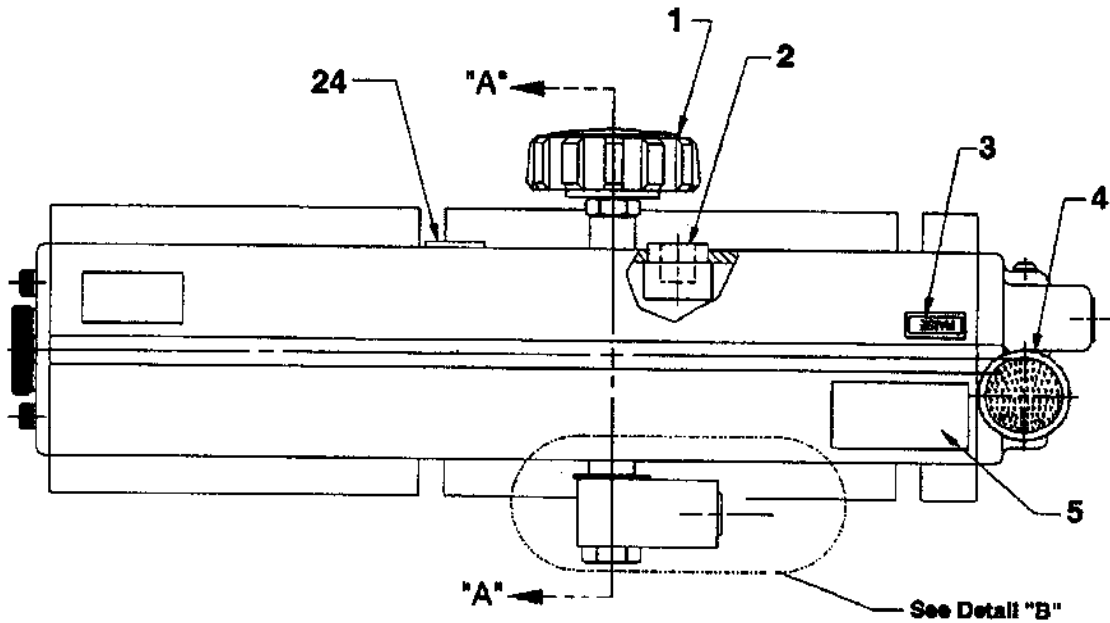

PANZITTA SALES & SERVICE
 72 George Avenue
 Wilkes-Barre, PA 18705
 570-822-6720 800-822-6720
 www.panzittasales.com

ITEM	QTY.	DESCRIPTION	PART #
1	1	KNOB	6-2378
2	2	MUFFLER	6-2379*
3	1	DECAL	6-2380
4	1	KNOB	6-2381
5	1	WARNING DECAL	6-2382
6	1	COMPRESSION SPRING	6-2383
7	1	PIVOT CAM	6-2384
8	1	O-RING	6-2385*
9	2	O-RING	6-2386*
10	1	STEEL BALL, 7/32"	6-2387*
11	1	BALL GUIDE	6-2388
12	1	COMPRESSION SPRING	6-2389*
13	1	BUSHING	6-2390
14	1	RETAINING RING	6-2391
15	1	SWIVEL BLOCK	6-2392
16	1	PLUG FITTING	6-2393
17	1	FILTER DISC	6-2394*
18	1	RETAINING RING	6-2395*
19	1	POPPET RETAINER	6-2396
20	1	POPPET	6-2397
21	2	BACKUP WASHER	6-2398*
22	2	O-RING	6-2399*
23	1	SWIVEL FITTING	6-2400
24	1	DECAL	6-2401
25	1	WASHER	6-2402
	NOTE:	PART NUMBERS MARKED WITH AN ASTERIX (*) ARE CONTAINED IN REPAIR KIT NUMBER 6-2404	

PANZITTA SALES & SERVICE
 72 George Avenue
 Wilkes-Barre, PA 18705
 570-822-6720 800-822-6720
www.panzittasales.com