



WHEELTRONIC LTD.

INSTALLATION and OPERATION MANUAL

PANZITTA SALES & SERVICE
72 George Avenue
Wilkes-Barre, PA 18705
570-822-6720 800-822-6720
www.panzittasales.com



MID RISE
MODEL 6000A / 6000E
6,000 LB. CAPACITY

**READ and SAVE THIS
INSTRUCTION MANUAL**



WHEELTRONIC LTD.

6500 Millcreek Drive
Mississauga, Ontario
Canada L5N 2W6
1-800-268-7959

JUNE 2003

6-0944

MID-RISE MAIN FRAME ASSEMBLY

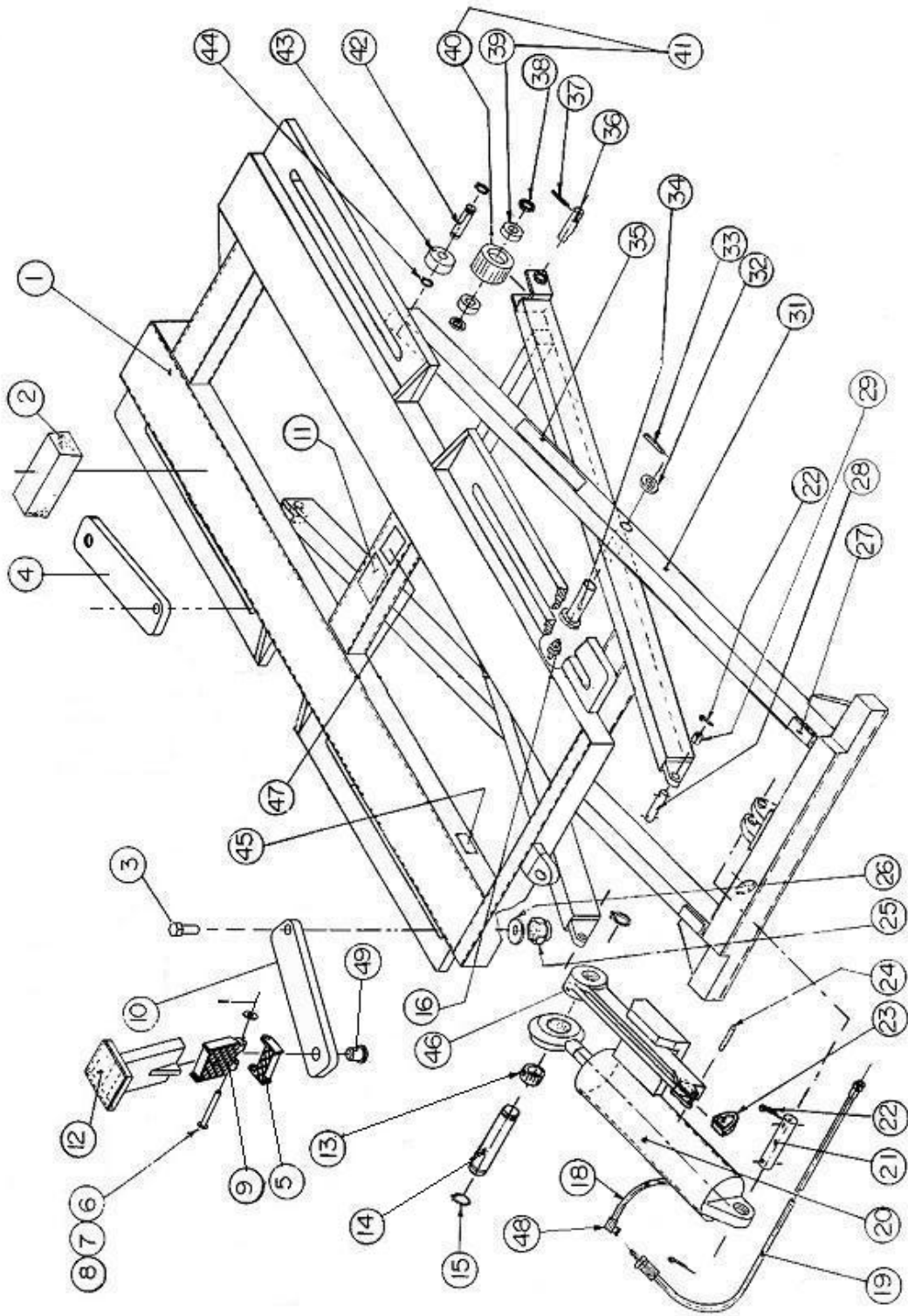

MID-RISE MAIN FRAME ASSEMBLY - PARTS LIST

ITEM NO.	QTY.	DESCRIPTION	PART NO.
1	1	TOP RAMP ASSEMBLY	4-0200
2	4	RUBBER BLOCK	6-1074
3	4	ARM BOLT	1-1076
4	2	ARM ASSEMBLY L.H.	2-1809
5	4	LOW ADAPTER	3-0583
6	4	CENTER PIN	1-1099
7	4	FLAT WASHER 1/2" I.D.	6-0063
8	4	COTTER PIN 1/8" X 1" LG.	6-0267
9	4	HIGH STEP ADAPTER	3-0582
10	2	ARM ASSEMBLY R.H.	2-1808
11	1	SERIAL PLATE	6-0763
12	2	TRUCK PAD ADAPTER (OPTIONAL)	2-0603
13	1	BUSHING	6-0976
14	1	SHAFT CYLINDER MOUNT	1-0814
15	2	CIRCLIP	6-0340
16	3	GREASE NIPPLE	6-0000
18	1	HYDRAULIC HOSE 19" LG.	1-0858
19	1	HYDRAULIC HOSE 12 FT LG.	2-0602
20	1	HYDRAULIC CYLINDER ASSEMBLY	4-0199
21	1	CYLINDER PIN	1-0861
22	6	COTTER PIN 1/8"-1 1/2" LG.	6-0978
23	1	OVERRIDE SAFETY CAM	2-0819
24	1	SPRING PIN 1/4" X 1 1/2" LG.	6-0745
25	4	UNI-TORQUE LOCK NUT 1"-8UNC	1-1385
26	4	FLAT WASHER 1" I.D.	6-1106
27	4	NEOPRENE STRIP	6-0993
28	2	HINGE PIN	1-0857
29	2	BUSHING	6-0795
31	1	SCISSOR ASSEMBLY	4-0203
32	2	KEEPER WASHER	1-0725
33	2	SPRING PIN 3/16" X 2" LG.	6-0146
34	2	SCISSOR PIN	1-0838
35	1	DECAL	6-0762
36	2	PIN	1-0837
37	2	SPRING PIN 3/16" X 1 1/4" LG.	6-0749
38	4	WASHER 7/8" I.D.	6-0725
39	4	BEARING	6-0751
40	2	ROLLER	1-0807
41	2	ROLLER ASSEMBLY KIT	0-0191
42	2	TRACK ROLLER SHAFT	1-0823
43	2	TRACK ROLLER (UPPER)	6-0750
44	4	CIRCLIP	6-0752
45	1	ALI PLATE	6-0398
46	1	SAFETY LOCK MECHANISM	3-0352
47	1	ETL/ALI STICKER	6-0996
48	1	3/8" NPT-F 90 DEGREE HYDRAULIC STEEL FITTING	6-0006
49	4	ADAPTER PIN	1-1091

HYDRAULIC CYLINDER ASSEMBLY

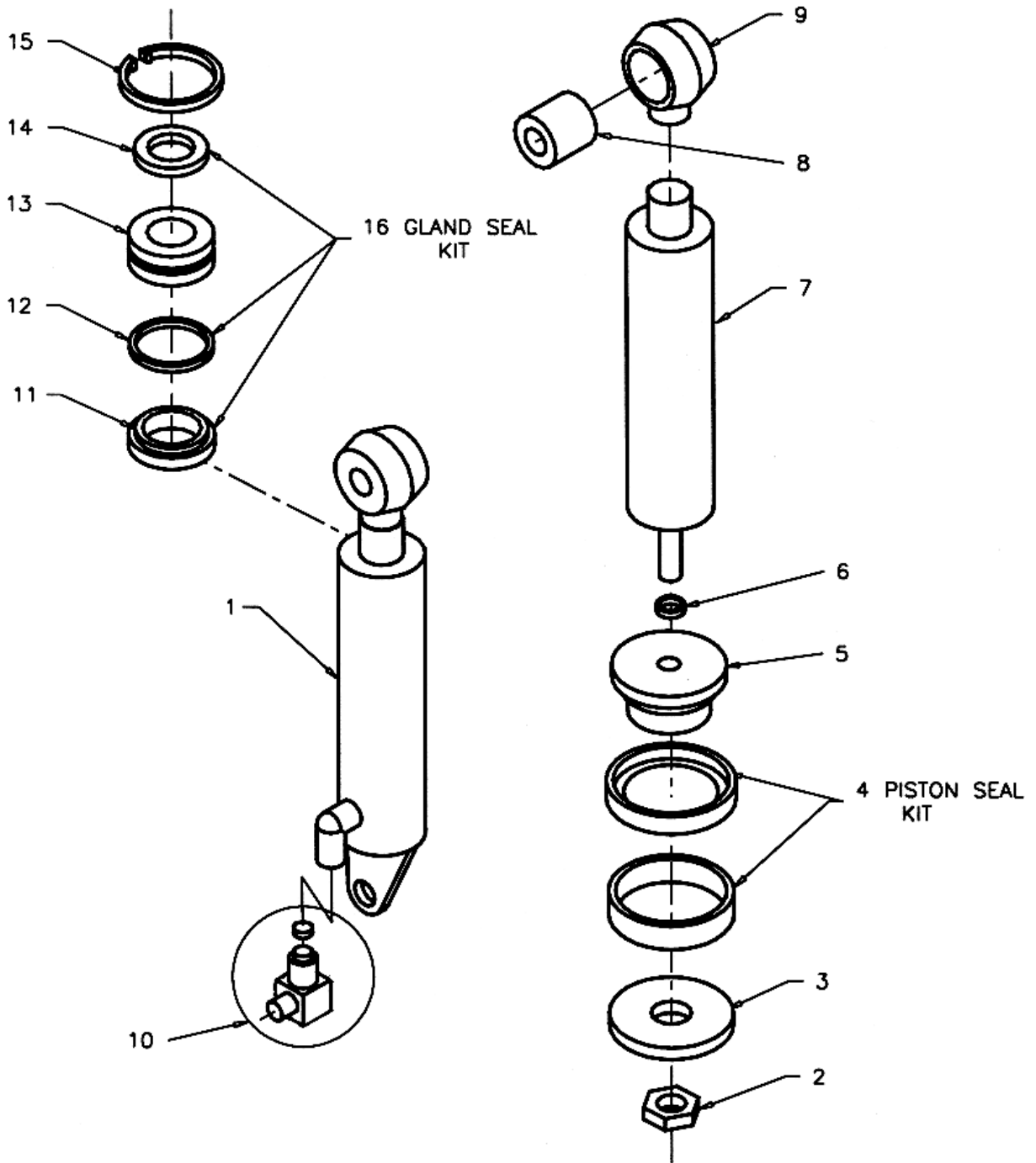

HYDRAULIC CYLINDER ASSEMBLY - PARTS LIST

ITEM NO.	QTY.	DESCRIPTION	PART NO.
1	1	CYLINDER TUBE WELDMENT	3-0350
2	1	7/8"-9UNC HEX LOCKNUT	6-0631
3	1	WASHER, 7/8" I.D.	1-0809
4	1	PISTON SEAL KIT	0-0181
5	1	PISTON	2-0586
6	1	"O" RING	6-0656
7	1	PISTON ROD	2-0832
8	1	BEARING	6-0976
9	1	ROD CLEVIS	2-0833
10	1	90° VELOCITY FUSE ASS'Y	1-1726
11	1	ROD SEAL	6-0754
12	1	"O" RING	6-0756
13	1	GLAND	2-0587
14	1	WIPER	6-0001
15	1	CIRCLIP	6-0755
16	1	GLAND SEAL KIT	0-0183

POWER PACK TOW CART

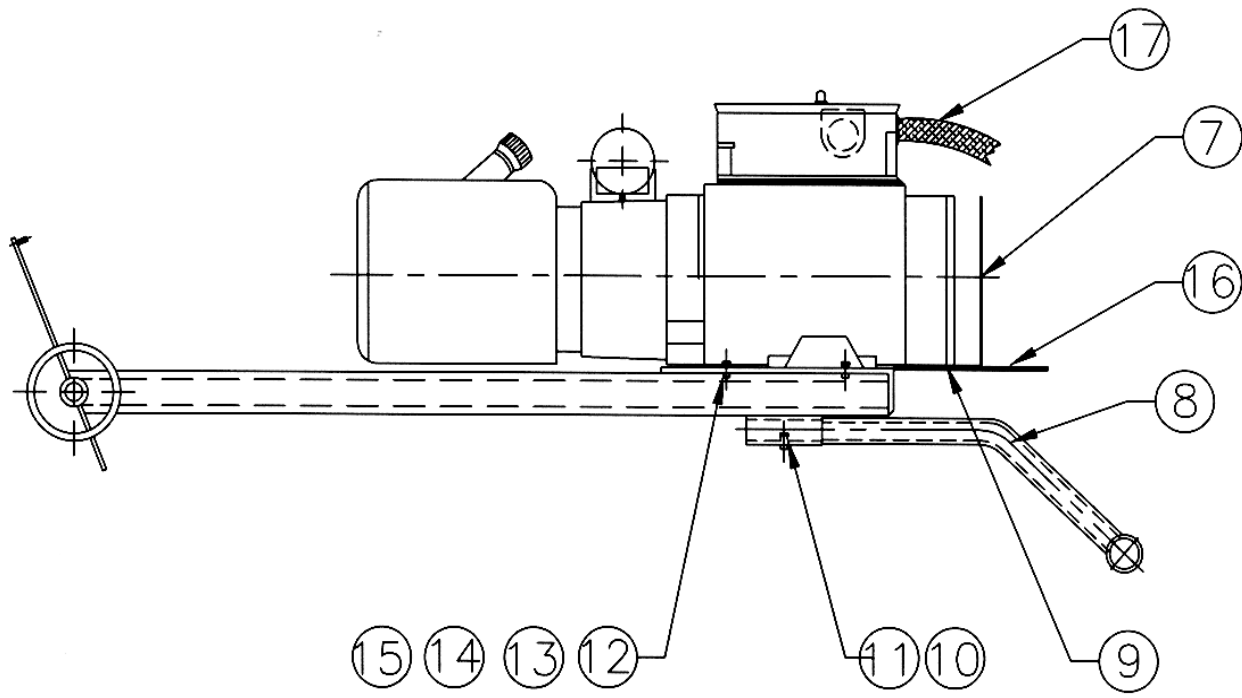
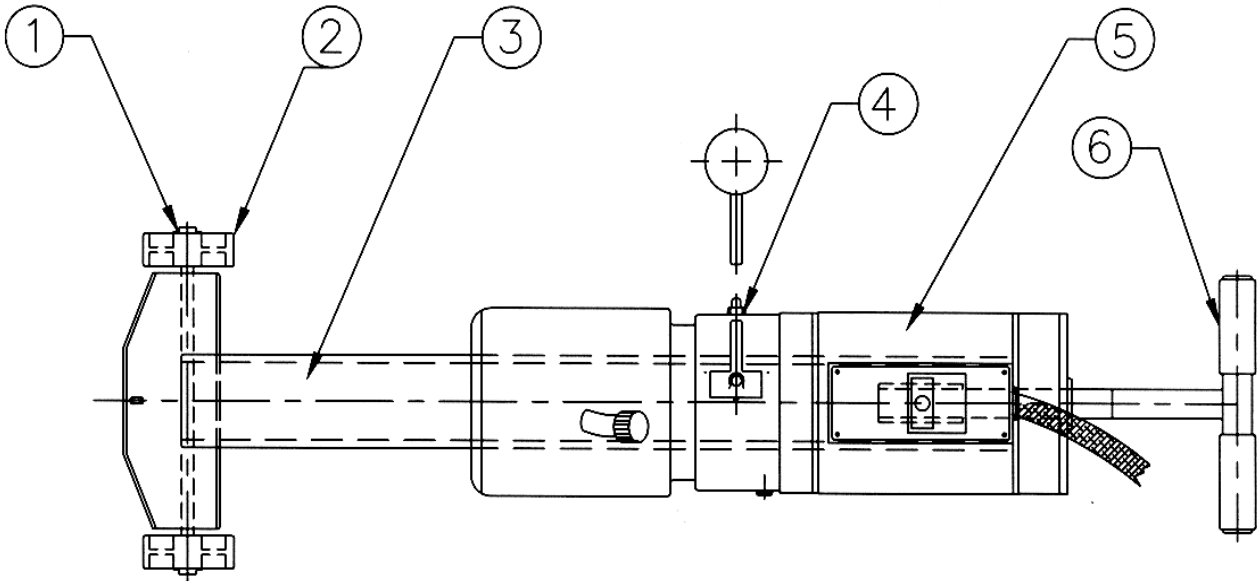

POWER PACK TOW CART - PARTS LIST

ITEM NO.	QTY.	DESCRIPTION	PART NO.
1	2	HUB CAP NUT	6-1833
2	2	WHEEL	6-0753
3	1	STAND (WITH WHEELS AND HUB CAP NUTS)	4-0207-01
4	1	ADAPTER-MACHINED W/ ORIFICES (.035"DIA)	1-1063
5	1	POWER PACK 115/230V 1PH 60HZ 1 HP	6-2249
6	2	GRIP HANDLE	6-0758
7	1	DECAL "OPERATING INSTRUCTIONS"	6-0759
8	1	"T" HANDLE (WITH GRIPS AND HARDWARE)	3-0408-01
9	1	BRACKET	1-0853
10	1	HEX BOLT 1/4"-20UNC X 3/4" LG.	6-0178
11	1	LOCKWASHER 1/4" I.D.	6-0056
12	4	HEX BOLT 5/16"-18UNC X 3/4" LG.	6-0423
13	4	LOCKWASHER 5/16" I.D.	6-0674
14	4	FLAT WASHER 5/16" I.D.	6-0295
15	4	HEX NUT 5/16"-18UNC	6-0294
16	1	ALI PLACARD	6-0990
17	1	PLUG	6-1711
*	1	COMPLETE TOWCART W/ ELECTRIC POWER PACK	4-0206

-SEE NEXT PAGE FOR THE POWER PACK ASSEMBLY

POWER PACK: #6-2249 (AB-1425) 115-230V/1PH/60Hz

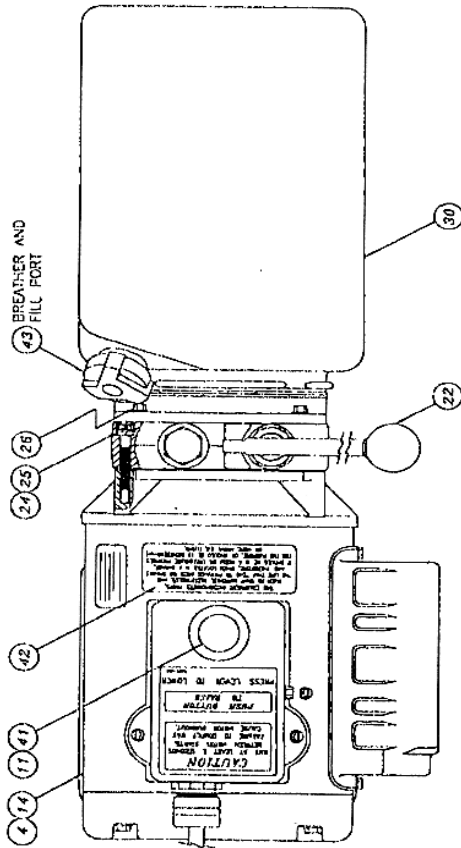
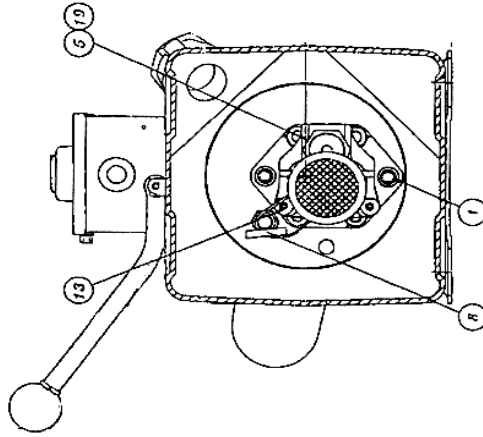
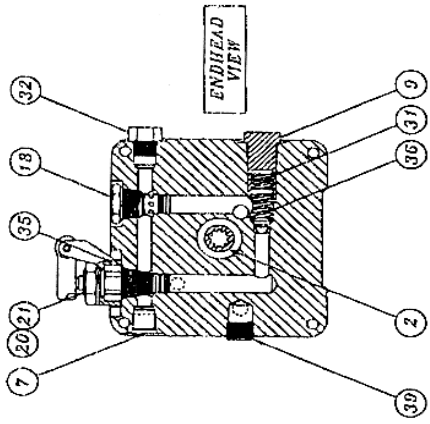

SERIES		WHEELTRONIC
SYMBOL NUMBER		TIME_SWITCH
BILL CODE		DRILL NUMBER
		AB-1425
FACTORY		AMPS at maximum
		3500
115 VAC		15
		3500
Factory (The Power Mfg. Division, E.)		

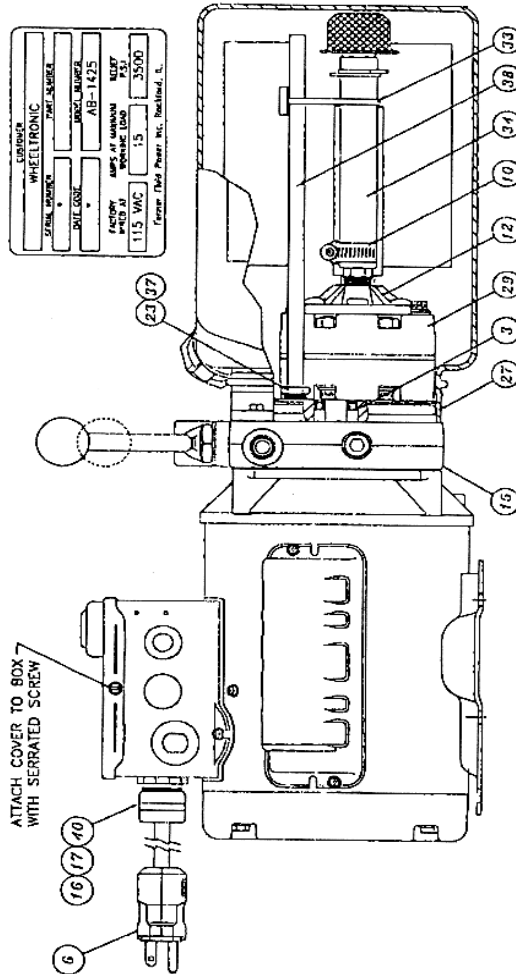

POWER PACK PARTS LIST: #6-2249 (AB-1425) 115-230V/1PH/60Hz

ITEM PART #	QTY.	DESCRIPTION	
1	2	BOLT 5/16"-24 x 2 3/4" TORX G8	6-2298
2	1	COUPLING SAE 9T-20/40 1.260"	6-0774
3	1	SEAL SHAFT 0.500" x 1.00" x 0.25"	6-2158
4	1	MOTOR AC PSC #613000 115/230 1 HP 1PH BLK	6-2299
5	1	WASHER 0.338" x 0.625" x 0.060" STEEL	6-2159
6	1	CORDSET 16/3 SJO 8FT 115V PLUG	6-2300
7	1	PACKAGE PLUG 9/16" SAE	6-2301
8	1	PLUMBING MAGNET	6-2162
9	1	RELIEF VALVE CAP ASSEMBLY	6-1089
10	1	PLUMBING CLAMP HOSE ADJ INLET	6-2166
11	2	ELECTRIC STAKE-ON NUT	6-2302
12	1	COVER ASS'Y SUCTION	6-2165
13	2	SCREW TAPTITE M6x1.0 12MM TORX	6-2164
14	1	NAMEPLATE, SERIAL	
15	1	ENDHEAD UNIVERSAL AUTOHOIST	6-2155
16	1	ELECTRIC CORD GRIP 3/4" NPT	6-2303
17	1	ELECTRIC PIPENUT 3/4"	6-2304
18	1	VALVE CARTRIDGE CHECK	6-1087
19	1	VALVE LOAD DELAY	6-2305
20	1	NUT 3/4"-16 x 1"HEX x 0.250 STEEL	6-2167
21	1	WASHER 3/4" INT. TOOTH LOCK	6-2168
22	1	BRACKET HANDLE ASS'Y REL BLACK	6-0776
23	1	COMPRESSION TUBE NUT	6-2153
24	4	BOLT M6 x 1.0 35MM SOC HD	6-2169
25	4	WASHER 1/4" LOCK HI-COLLAR	6-2170
26	4	BOLT #12-24 x .50 HEX WSHRHD	6-1091
27	1	O-RING 2-348 BUNA	6-0875
28	1	COVER ASSY SUCTION	6-2165
29	1	PUMP ASS'Y 0.8 SHORT SPLINE	6-2306
30	1	TANK PLASTIC 6.7 CT 11.0" BLACK	6-2307
31	1	SPRING 0.480" x 0.063" x 0.42" COMP	6-2151
32	1	PLUMBING PLUG 5/16" SAE	6-2157
33	1	CABLE TIE 8" LONG WHITE	6-1846
34	1	PLUMBING ASS'Y INLET 6.61 (3)	6-2308
35	1	VALVE CARTRIDGE RELEASE MANUAL	6-0880
36	1	RELIEF ASSEMBLY FIXED 260 BAR	6-1326
37	1	COMPRESSION TUBE SLEEVE	6-2154
38	1	RETURN HOSE 3/8" OD x 10.0"	6-2310
39	1	PLUMBING PLUG 3/8"NPT	6-2161
40	2	ELECTRIC REDUCER WASHER	6-2311
41	1	WIRING ASSEMBLY AC 1PH FENNER	6-2156
42	1	LABEL INSTALLATION AUTOHOIST	6-2136
43	1	BREATHING CAP & BLADDER	6-1376

AIR POWER PACK TOW CART

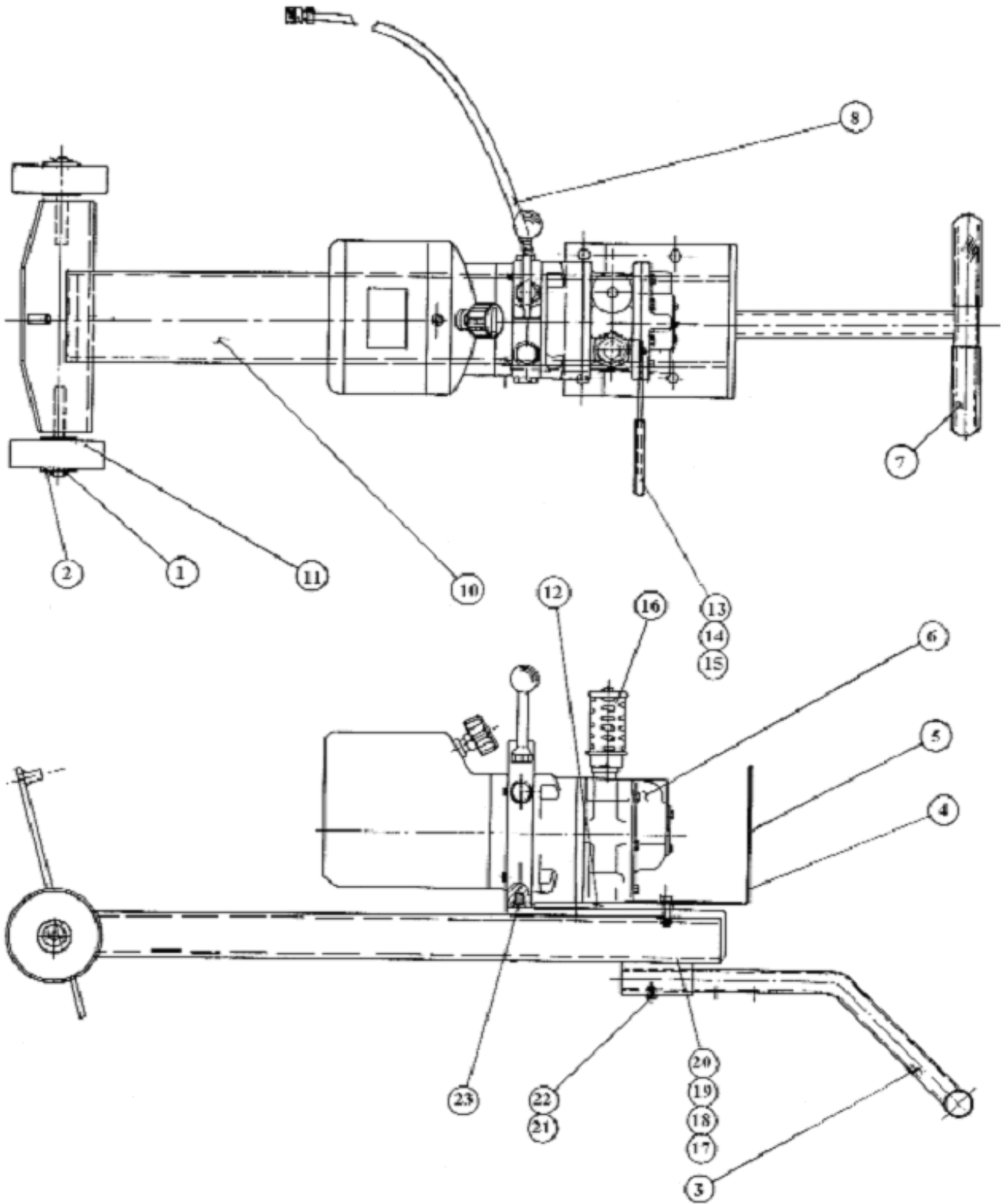

AIR POWER PACK TOW CART - PARTS LIST

ITEM NO.	QTY	DESCRIPTION	PART NO.
1	2	1 /2" PUSHNUT	6-1833
3	1	"T" HANDLE (WITH GRIPS AND HARDWARE)	3-0408-01
4	1	BRACKET	1-0853
5	1	DECAL "OPERATING INSTRUCTIONS"	6-0759
6	1	AIR HYDRAULIC PUMP "AC-10TC UTILIZING VA-4S VANE AIR MOTOR"	6-0919
7	2	GRIP HANDLE	6-0758
8	1	HYDRAULIC HOSE - 12FT.	2-0602
10	1	STAND (WITH WHEELS AND HUB CAP NUTS)	4-0207-01
11	2	WHEEL	6-0753
12	1	MOTOR MOUNT BRACKET	2-0739
13	1	BALL VALVE	6-0940
14	1	3/8" STEEL NIPPLE	6-0953
15	1	REDUCER 3/4" M PIPE/ 3/8" F PIPE	6-0285
16	1	EXHAUST MUFFLER	6-0958
17	4	LOCKWASHER 5/16" I.D.	6-0674
18	4	HEX BOLT 5/16"-18UNC X 3/4" LG.	6-0423
19	4	FLAT WASHER 5/16" I.D.	6-0295
20	2	HEX. NUT 5/16"-18UNC	6-0294
21	1	HEX BOLT 1/4"-20UNC X 3/4" LG.	6-0178
22	1	LOCKWASHER 1/4" I.D.	6-0056
23	1	FLAT HD. SCREW - 3/8" - 16 x 1/2" LG.	6-0955
*	1	COMPLETE TOWCART W/ AIR POWER PACK	4-0274