

PANZITTA SALES & SERVICE
72 George Avenue
Wilkes-Barre, PA 18705
570-822-6720 800-822-6720
www.panzittasales.com

PARTS MANUAL

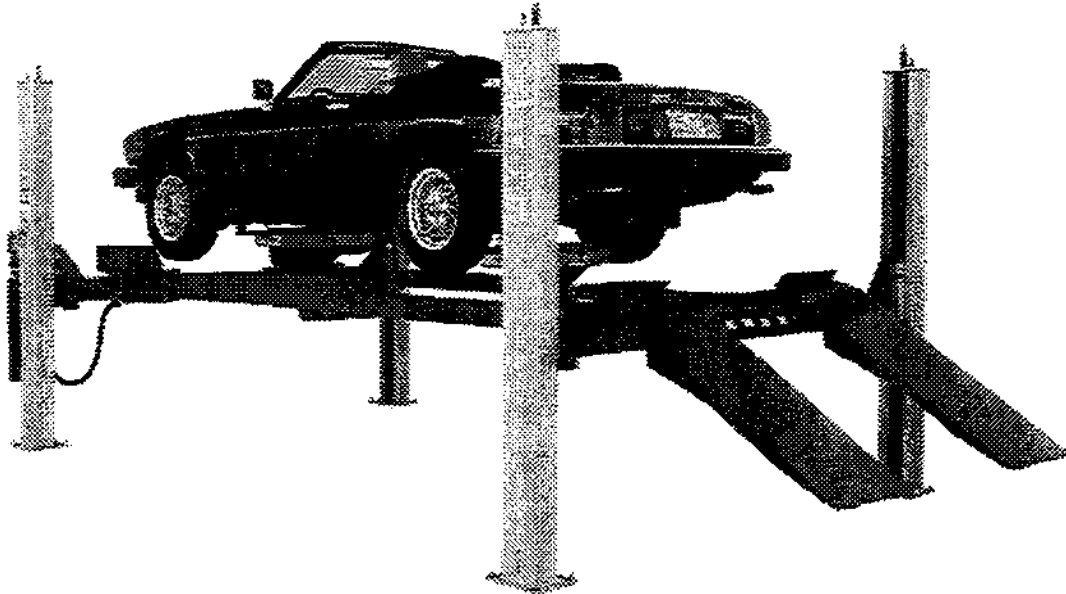

QUATRO 4 - POST

(MODEL 44110 Q)

10,000 LB.

PARTS LIST

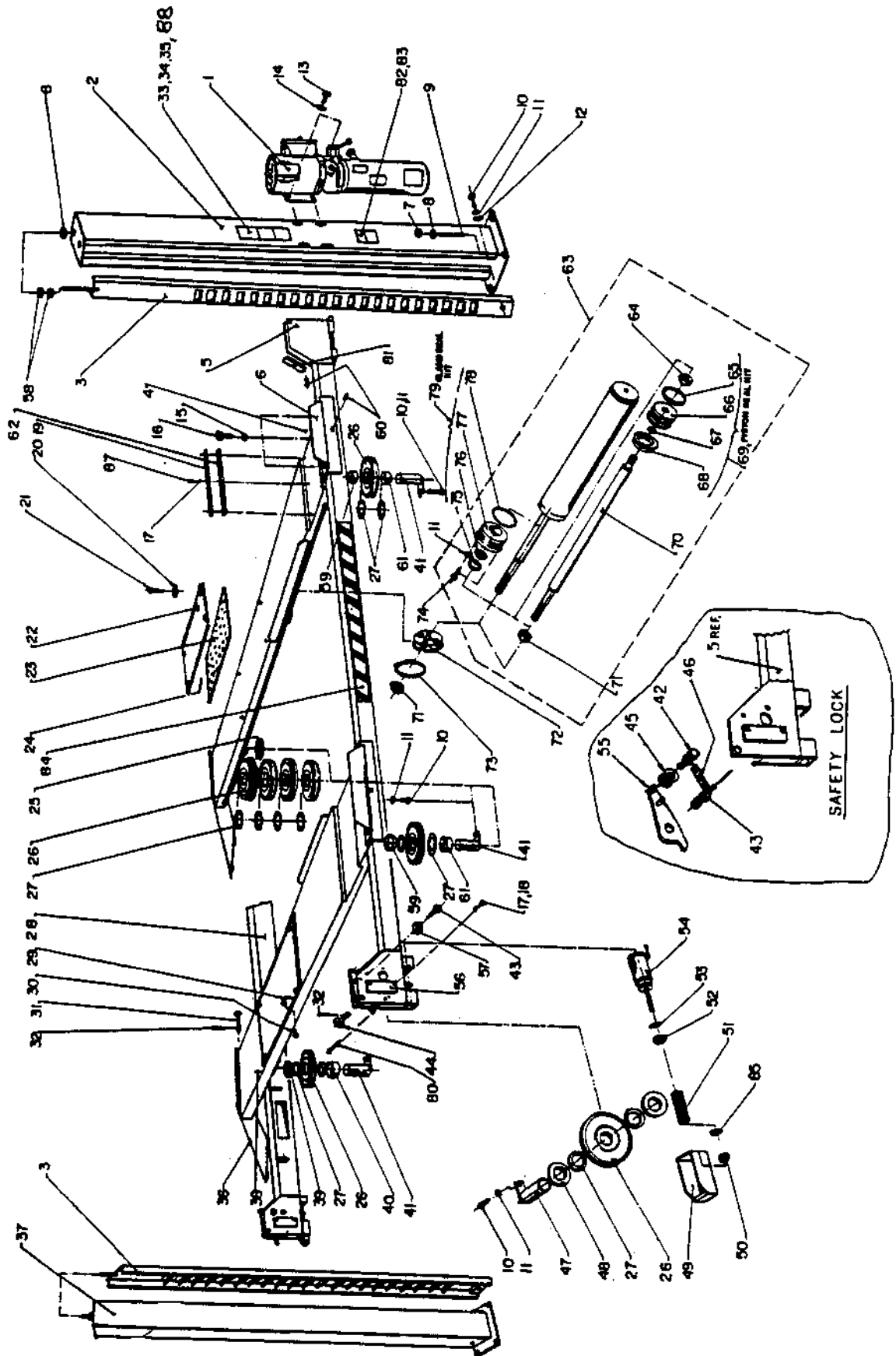

PARTS LIST

ITEM	QTY.	DESCRIPTION	PART#
1	1	POWER PACK, 220V/1PH	6-0650
2	1	POWER POST	4-0186
3	4	SAFETY RACK	3-0487
4	1	ALIGNMENT DECK WLDMT, (LEFT SIDE)	4-0357
5	1	FRONT CROSSMEMBER WELDMENT	4-0342
6	2	FRONT WHEEL STOP WELDMENT	2-0989
7	16	HEX NUT, 3/4"-10UNC	6-0737
8	20	FLAT WASHER, 3/4" I.D.	6-0738
9	16	WEDGE ANCHOR, 3/4"-10UNC X 4 3/4" LG.	6-0736
10	12	HEX HD. BOLT, 3/8"-16UNC X 1" LG. GR.8	6-0668
11	14	LOCKWASHER, 3/8" I.D.	6-0058
12	4	FLAT WASHER, 3/8" I.D.	6-0062
13	4	HEX HD. BOLT, 5/16"-18UNC X 3/4" LG.	6-0423
14	4	LOCKWASHER, 5/16" I.D.	6-0674
15	6	LOCKWASHER, 1/2" I.D.	6-0059
16	6	HEX HD. BOLT, 1/2"-13UNC X 1" LG.	6-0045
17	28	LOCKWASHER, 1/4" I.D.	6-0056
18	16	HEX HD. BOLT, 1/4"-20UNC X 3/4" LG.	6-0178
19	4	RETAINING BAR	2-0635
20	8	FLAT WASHER, 13/32" I.D. X 2" O.D.	6-0426
21	8	SHOULDER BOLT, 3/8" DIA. X 5/8" LG.	6-0069
22	2	REAR SLIP PLATE WELDMENT	3-0503
23	2	BEARING CAGE	1-1070
24	1	BALL BEARING SET	6-0829
25	1	SHEAVE SPACER, 1/2" LG.	1-0787
26	11	SHEAVE ASSEMBLY	2-0557
27	19	NYLON THRUST WASHER	1-0757
28	1	REAR CROSSMEMBER WELDMENT	4-0341
29	4	LOCKING PIN ASSEMBLY	2-0637
30	4	SELF TAPPING SCREW, #10 X 1/2" LG.	6-0505
31	2	RAMP PIN	1-0095
32	6	COTTER PIN, 1/8" X 2" LG.	6-0115
33	1	"CAUTION" DECAL	6-0592
34	1	"SAFETY INSTRUCTIONS" DECAL	6-0351
35	1	"WARNING" DECAL	6-0595
36	2	APPROACH RAMP WELDMENT	3-0502
37	3	POST	3-0347
38	1	ALIGNMENT DECK WLDMT, (RIGHT SIDE)	4-0358
39	1	SHEAVE SPACER, 2 1/2" LG.	1-0798
40	1	SHEAVE SPACER, 1 1/2" LG.	1-0788

ITEM	QTY.	DESCRIPTION	PART#
41	4	DECK SHEAVE PIN	2-0566
42	4	SHOULDER BOLT, 3/8"DIA. X 1 1/2"LG.	6-0801
43	12	SHOULDER BOLT, 3/8"DIA. X 3/4"LG.	6-0729
44	4	LOCK SAFETY PIN	1-0769
45	4	CABLE ROLLER	1-0766
46	4	TENSION SPRING	1-0768
47	4	CROSSMEMBER SHEAVE PIN	1-0771
48	8	SHEAVE SPACER, 3/8"LG.	1-0786
49	4	SAFETY SHOE WELDMENT	2-0990
50	4	HEX NYLON LOCKNUT, 1/4"-28UNF	6-1563
51	4	COMPRESSION SPRING	1-0767
52	4	HEX NUT, 5/8"-18UNF	6-0662
53	4	INTERNAL TOOTH LOCKWASHER, 5/8" I.D.	6-0663
54	4	AIR CYLINDER, 5 1/2" ROD LG. (SPR-12)	6-0651
55	4	SAFETY LOCK WLDMT.	2-0567
56	8	PLASTIC BRACKET	1-0775
57	8	PLASTIC GUIDE	1-0776
58	8	HEX NUT, 5/8"-11UNC, GR.8	6-0036
59	2	SHEAVE SPACER, 1 3/4"LG.	1-0799
60	8	SET SCREW, 1/2"-13UNC X 1"LG. GR.8	6-0726
61	2	SHEAVE SPACER, 2"LG.	1-0943
62	4	SPACER BAR	2-0636
63	1	HYDRAULIC CYLINDER	4-0187
64	1	LOCKNUT, 7/8"- 14UNF, NYLON INSERT	6-1160
65	1	WEAR RING	6-0004
66	1	PISTON	2-0564
67	1	"O" RING	6-1305
68	1	PISTON SEAL	6-0003
69	1	PISTON SEAL KIT	0-0169
70	1	PISTON ROD	2-0565
71	2	HEX NUT, 1"-14UNF-2A, GR.8	6-0664
72	1	CABLE FLANGE	2-0561
73	1	CLAMP	6-0665
74	2	HEX HD. BOLT, 3/8"-16UNC X 1 1/4"LG. GR.8	6-0666
75	1	ROD WIPER	6-0653
76	1	ROD SEAL	6-0654
77	1	GLAND	3-0348
78	1	"O" RING	6-0655
79	1	GLAND SEAL KIT	0-0170
80	4	HEX HD. BOLT, 3/8"-16UNC X 2 3/4"LG.	6-0730
81	4	SHEAVE COVER	2-0575

ITEM	QTY.	DESCRIPTION	PART#
82	1	SERIAL TAG	6-1114
83	1	"ALI/ETL" TAG	6-0996
84	2	"CAUTION" TAPE, (40"LG.)	6-1125
85	8	FLAT WASHER, 1/4" I.D.	6-0060
87	12	HEX HD. BOLT, 1/4"-20UNC X 1 1/4" LG.	6-0027
88	1	"ATTENTION" DECAL	6-1637

PANZITTA SALES & SERVICE
 72 George Avenue
 Wilkes-Barre, PA 18705
 570-822-6720 800-822-6720
www.panzittasales.com

HYDRAULIC AND AIR KITS PART LIST

ITEM	QTY.	DESCRIPTION	PART#
1	8	90° ELBOW, 1/8"NPT X 1/4"POLY TUBE	6-0709
2	4	AIR CYLINDER	6-0651
3	50 FT.	1/4" DIA. POLY TUBE	6-0706
4	4	ADAPTER, 3/8" POLY TUBE X 1/4"NPT	6-0710
5	2	TERMINAL BOLT, 3/4"	6-0713
6	2	PLUG, 1/4"NPT	6-0282
7	4	1/4" NPT STREET TEE	6-0014
8	2	1/4" NPT STREET ELBOW	6-0015
9	25 FT.	3/8" DIA. POLY TUBE	6-0707
10	1	90° ADAPTER, 3/8"JIC M X 9/16"-18 M	6-0804
11	4 FT.	HOSE GUARD	6-0714
12	1	POWER PACK 230V/1 PH	6-0650
13	1	HYD.HOSE ASS'Y,3/8"SWIVELx3/8"JICM,147"LG.	6-0715
14	3	CABLE TIE	6-0731
15	2	HEX NUT, #8-32	6-1095
16	2	ADAPTER, 3/8"NPT M X 3/8"JIC F, SWIVEL	6-0797
17	1	FLOW CONTROL	6-0090
18	1	"NOTICE" DECAL	6-0594
19	1	90° ELBOW, 1/4"NPT M X 3/8"NPT F	6-0796
20	4	ADAPTER, 1/4" POLY TUBE X 1/8"NPT	6-0708
21	1	AIR VALVE	6-0717
22	1	AIR FILTER	6-0180
23	1	90° REDUCER, 1/4"NPT M X 1/8"NPT M	6-0718
24	1	VELOCITY FUSE	6-0025
25	1	PLUG, 1/8" NPT	6-0182
26	2	MANIFOLD	1-1057
27	4	HEX HD.CAP SCREW, 1/4"-20UNC X 1 1/2"LG.	6-0205
28	4	HEX NUT, 1/4"-20UNC	6-0032
29	4	LOCKWASHER, 1/4" I.D.	6-0056
30	2	PHIL. HD. SCREW, #8-32 X 1"LG.	6-1094
32	1	"LIFT OPERATION" DECAL	6-0593
33	1	ADAPTER, 1/8"NPT M X 1/4"JIC M	6-0280

PANZITTA SALES & SERVICE
 72 George Avenue
 Wilkes-Barre, PA 18705
 570-822-6720 800-822-6720
www.panzittasales.com

CABLE ROUTING

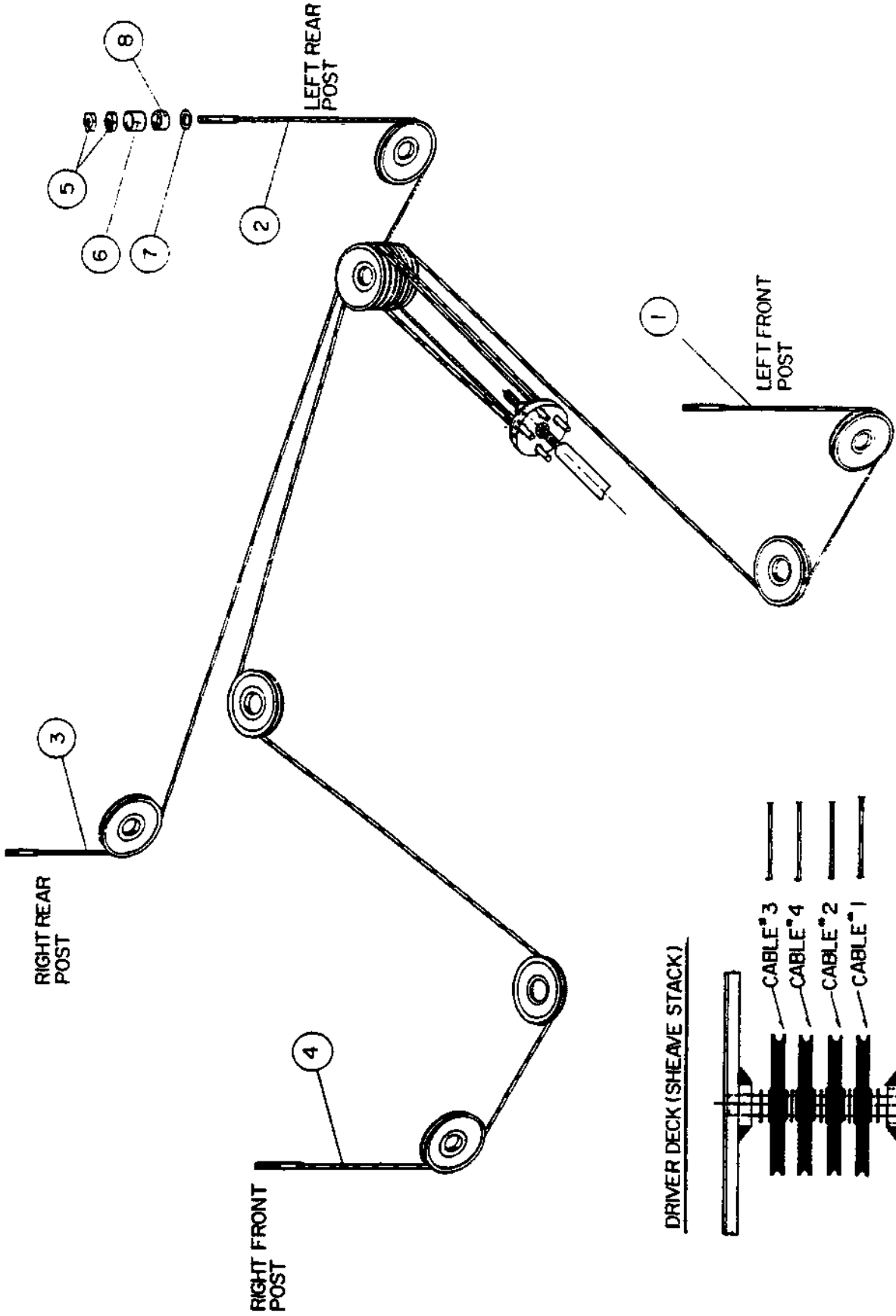

CABLE ROUTING

ITEM	QTY.	DESCRIPTION	PART#
1	1	CABLE ASSEMBLY, 314"LG. (LEFT-FRONT)	2-0943
2	1	CABLE ASSEMBLY, 144"LG. (LEFT-REAR)	2-0944
3	1	CABLE ASSEMBLY, 194"LG. (RIGHT-REAR)	2-0945
4	1	CABLE ASSEMBLY, 361"LG. (RIGHT-FRONT)	2-0946
5	8	HEX NUT, 7/8"-14UNF, GR.8	6-0724
6	4	CABLE SPACER, 2"LG.	1-0800
7	4	FLAT WASHER, 7/8" I.D.	6-0725
8	4	CABLE SPACER, 1"LG.	1-0801

PANZITTA SALES & SERVICE
72 George Avenue
Wilkes-Barre, PA 18705
570-822-6720 800-822-6720
www.panzittasales.com

POWER PACK

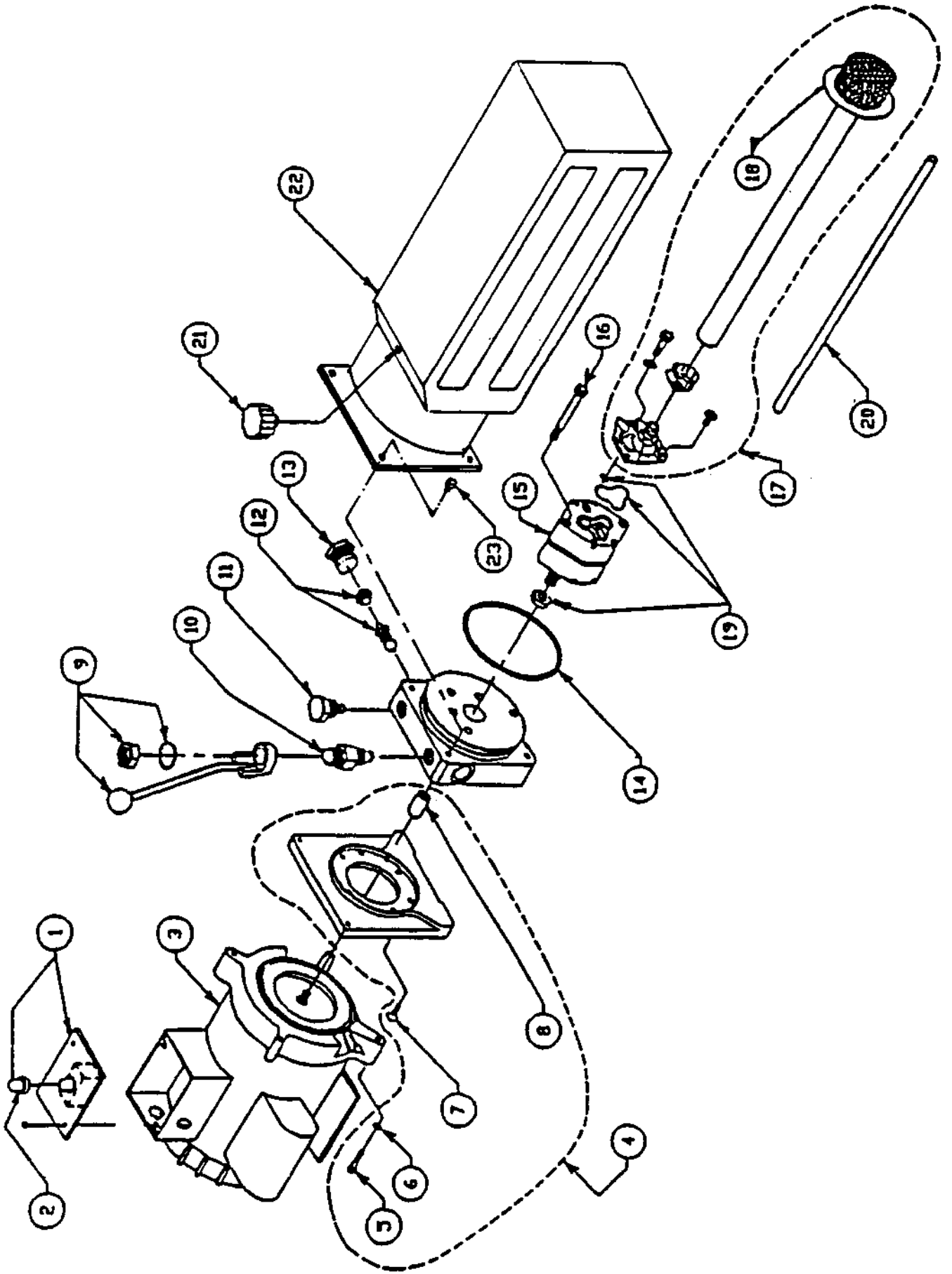

POWER PACK

ITEM	QTY.	DESCRIPTION	PART#
1	1	MICROSWITCH AND WIRING ASSEMBLY	6-0881
2	1	MICROSWITCH BOOT	6-1084
3	1	MOTOR, 230V AC, 1 PHASE, 60 Hz.	6-0773
4	1	MOTOR ADAPTER KIT	0-0197
5	4	SOCKET HD.CAP SCW. 1/4"-20UNC X 1 5/8"LG.	6-1085
6	4	LOCK WASHER, 1/4" I.D.	6-0056
7	4	ALLEN FLAT HD.SCW. 1/4"-20UNC X 3/4"LG.	6-1086
8	1	COUPLING	6-0774
9	1	RELEASE BRACKET & HANDLE ASSEMBLY	6-0776
10	1	VALVE CARTRIDGE RELEASE	6-0880
11	1	VALVE CARTRIDGE CHECK	6-1087
12	1	FIXED RELIEF VALVE (RV 17)	6-1317
13	1	RELIEF VALVE CAP	6-1089
14	1	RESERVOIR "O" RING	6-0875
15	1	PUMP ASSEMBLY	6-0782
16	2	PUMP MOUNTING BOLT	6-1090
17	1	INLET PLUMBING KIT	0-0198
18	1	INLET HOSE / FILTER ASSEMBLY	6-0786
19	1	PUMP "O" RING KIT	0-0199
20	1	RETURN TUBE	6-0783
21	1	BREATHER FILLER CAP	6-0784
22	1	RESERVOIR	6-0785
23	4	RESERVOIR SCREW	6-1091

PANZITTA SALES & SERVICE
72 George Avenue
Wilkes-Barre, PA 18705
570-822-6720 800-822-6720
www.panzittasales.com