

PANZITTA SALES & SERVICE

72 George Avenue

Wilkes-Barre, PA 18705

570-822-6720 800-822-6720

www.panzittasales.com

**ROTARY LIFT**

P.O. Box 30205, Memphis, TN 38130  
WORLD LEADER IN LIFT SYSTEMS

A DOVER INDUSTRIES COMPANY

**MODEL PFX-1**

**PARTS BREAKDOWN**

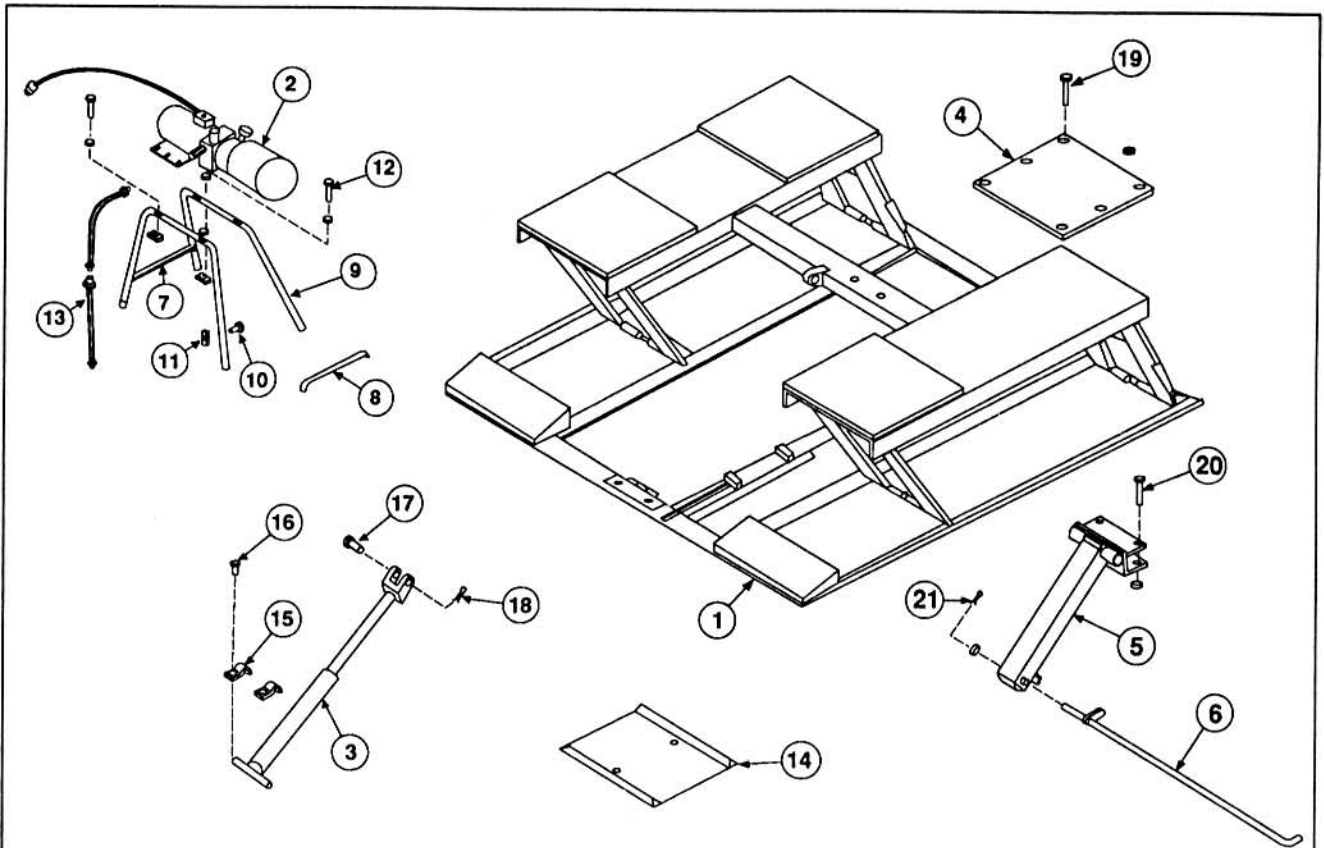

ITEM NO.	DESCRIPTION	PART NO.	ITEM NO.	DESCRIPTION	PART NO.
1	Superstructure	FJ2196	12	1/4"-20NC HHCS x 2" Lg.	(4) Req'd
2	Power Unit	P501	13	Hose	FJ801
3	Hydraulic Cylinder	FJ2173	14	Wheel Spotting Dish	FF729
4	Rubber Pad	FJ2195-3	15	Cylinder Clip	FJ294-4
5	Locking Leg	FA2191-1	16	1/2"-13NC x 1" Lg. HHCS	
6	Release Handle	FA2191-2	17	Clevis Pin	FJ294-3-1
7	Complete Power Unit Stand	FA566	18	Cotter Pin (3/16" x 1 1/2" Lg.)	
8	Bracket	FA566-1	19	1/4"-20NC x 1 1/4" Lg. PHS w/Nut	(9 per pad)
9	Leg	FA566-2	20	3/8"-16NC x 2 3/4" Lg. HHCS w/Nut	(2) Req'd
10	1/4"-20NC HHCS x 1" Lg.	(4) Req'd	21	Cotter Pin (1/8" x 1" Lg.)	
11	1/4"-20NC Unistrut Nut	(8) Req'd			

**OWNERS RECORD**

Complete information at right and keep in a safe place.

Date Installed     /    /    

Installed In Bay     

Serial #      P501

Factory Order #  L

**IMPORTANT:** When ordering parts or requesting service, always give exact model and jack serial number. Model number is shown on nameplate attached to superstructure. Jack serial number is located on side of plunger at point of attachment to superstructure.

**ROTARY LIFT**

A DOVER INDUSTRIES COMPANY

Printed in USA 8-89 (C) 500

PANZITTA SALES & SERVICE

72 George Avenue

Wilkes-Barre, PA 18705

570-822-6720 800-822-6720

www.panzittasales.com

INDEX 2.5.2