

PANZITTA SALES & SERVICE
 72 George Avenue
 Wilkes-Barre, PA 18705
 570-822-6720 800-822-6720
 www.panzittasales.com

ROTARY LIFT
 P.O. Box 1560 Madison, IN 47250
 WORLD LEADER IN LIFT SYSTEMS
 A **DOVER** INDUSTRIES COMPANY

**MODEL MR6E
 PARTS BREAKDOWN**

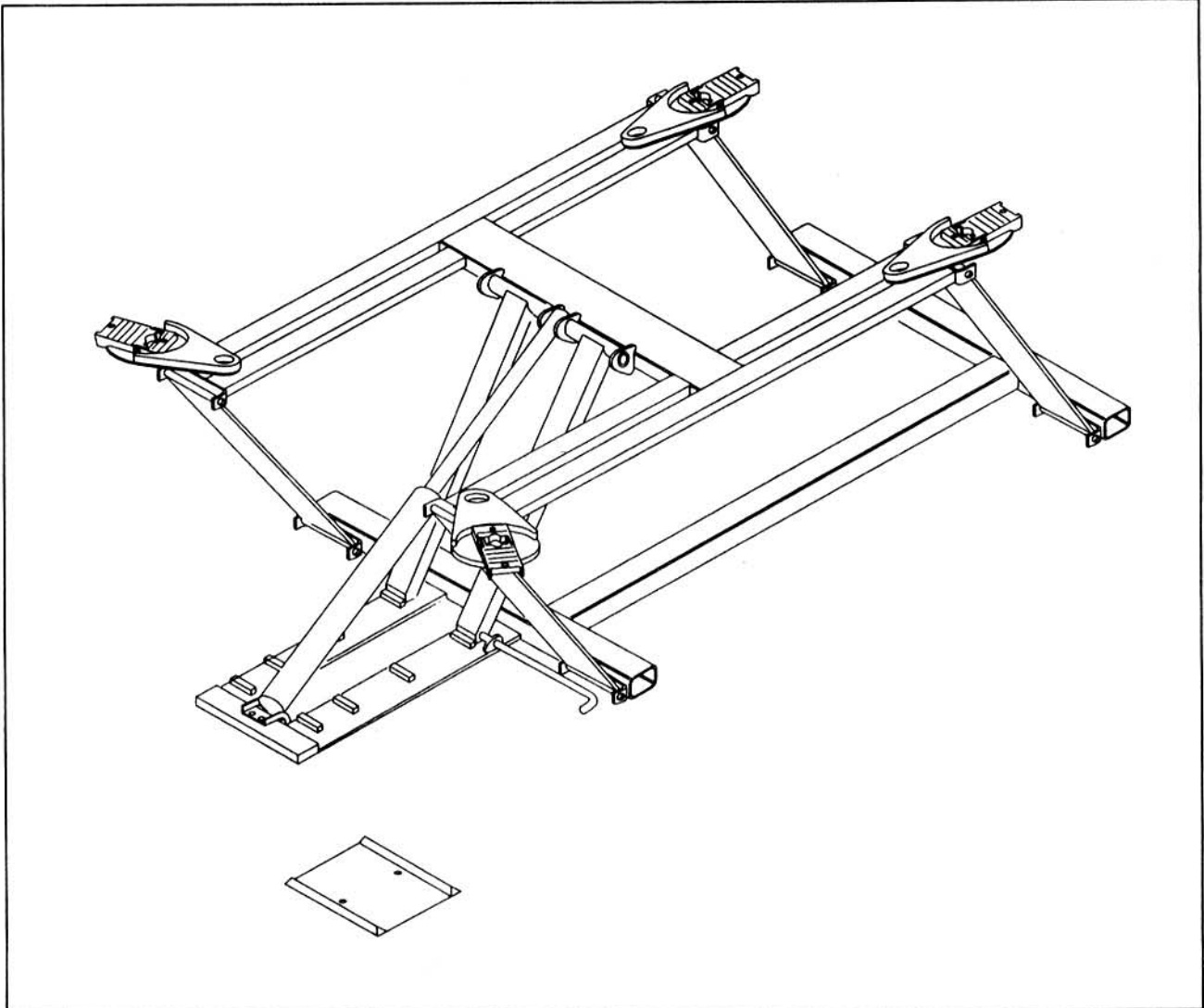

IMPORTANT: When ordering parts always give exact model and power unit serial number. Model number is shown on nameplate attached to center member of superstructure. Serial number is located on side of power unit reservoir.

NOTES:

OWNER'S RECORD

Complete information at right and keep in a safe place.

Date Installed _____
 Installed in Bay # _____
 Power Unit Serial # _____
 Factory Order # _____

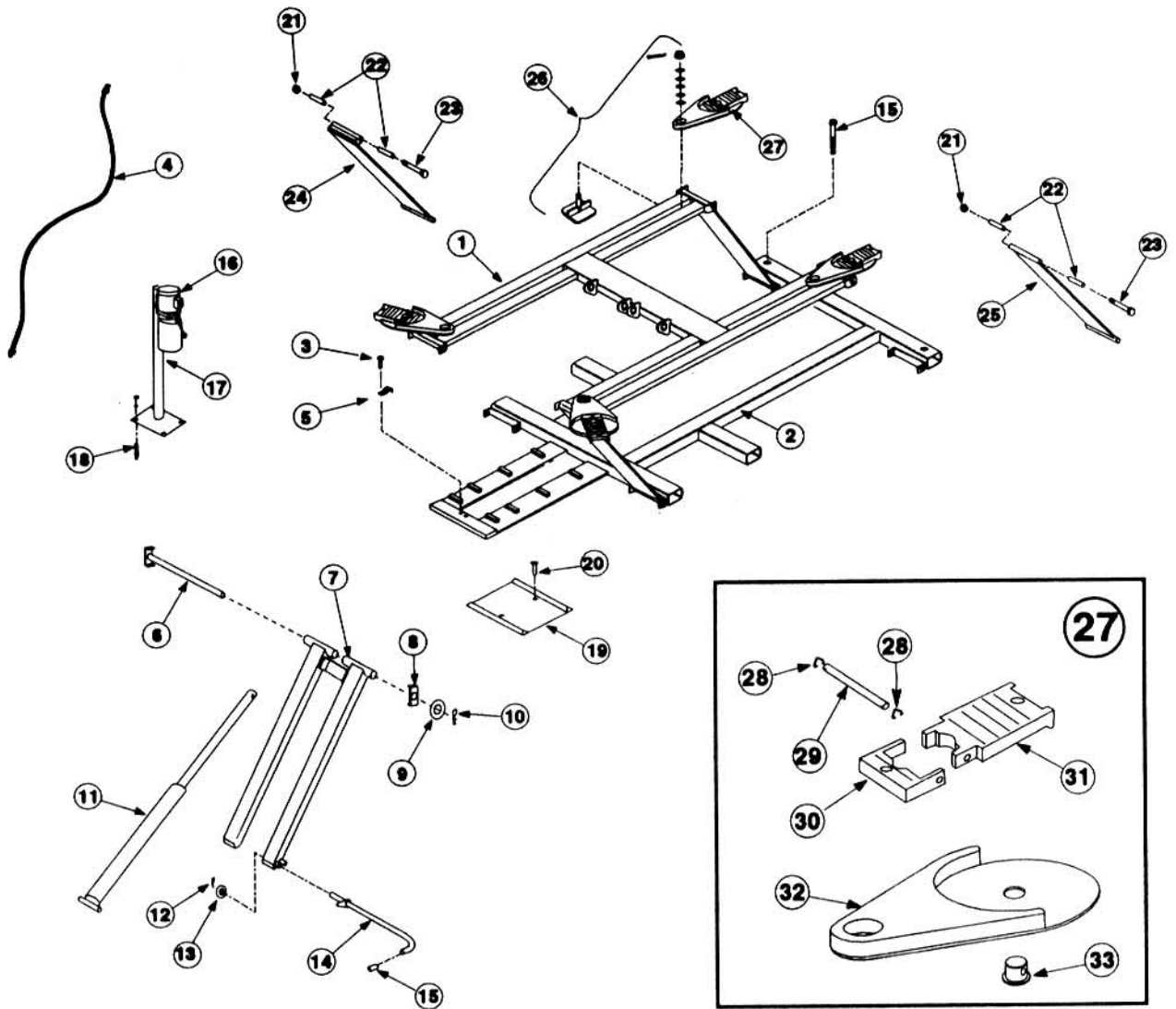

MR6 REPLACEMENT PARTS

ITEM NO.	DESCRIPTION	PART NO.	ITEM NO.	DESCRIPTION	PART NO.
1	Superstructure Assembly	FJ857	18	3/8" Concrete Anchor	FC5388-98
2	Base Assembly	FJ856	19	Wheel Spotting Dish	FF729-1
3	3/8" X 1" Flange Head Cap Screw	40144	20	Drive Anchor	FJ7659-2
4	Hose	FJ85	21	Nut	FJ2252-3
5	Cylinder Clip	FJ294-4	22	Hinge Bushing	FJ2264-21
6	Pin	FJ862	23	5/8"-11NC HHCS x 7" Lg. Gd. 8	40358
7	Locking Leg Assembly	FJ861	24	Front Leg Assembly	FJ858
8	Pin Retainer	FJ863	25	Rear Leg Assembly	FJ859
9	3/4" I.D. Washer	41020	26	Adapter Retainer Kit (Set of 4)	FJ2261
10	1/8" x 1 1/4" Lg. Cotter Pin	41201	27	Swivel Arm Adapter Assembly	FJ2311
11	Hydraulic Cylinder	FJ860	28	3/32" Hog Ring	FJ671-6
12	1/8" x 1" Lg. Cotter Pin	41200	29	Adapter Pin	FJ671-3
13	Machinery Bushing Washer	FJ2252-4	30	Low Step Adapter	FJ671-2
14	Release Handle	FJ2294-3	31	High Step Adapter	FJ671-1
15	End cap	FJ2281-8	32	Swivel Arm / Adapter Base	●
16	Power Unit	P787	33	Adapter Swivel Pin	FJ79-6
17	Power Unit Stand	FJ864			

●Note: If adapter base needs replacing, it is more economical to replace the entire adapter.