

PANZITTA SALES & SERVICE

72 George Avenue

Wilkes-Barre, PA 18705

570-822-6720 800-822-6720

www.panzittasales.com

**ROTARY LIFT**

P.O. Box 30205, Memphis, TN 38130  
WORLD LEADER IN LIFT SYSTEMS

A **DOVER** INDUSTRIES COMPANY

**MODEL PAL-5E**

**PARTS BREAKDOWN**

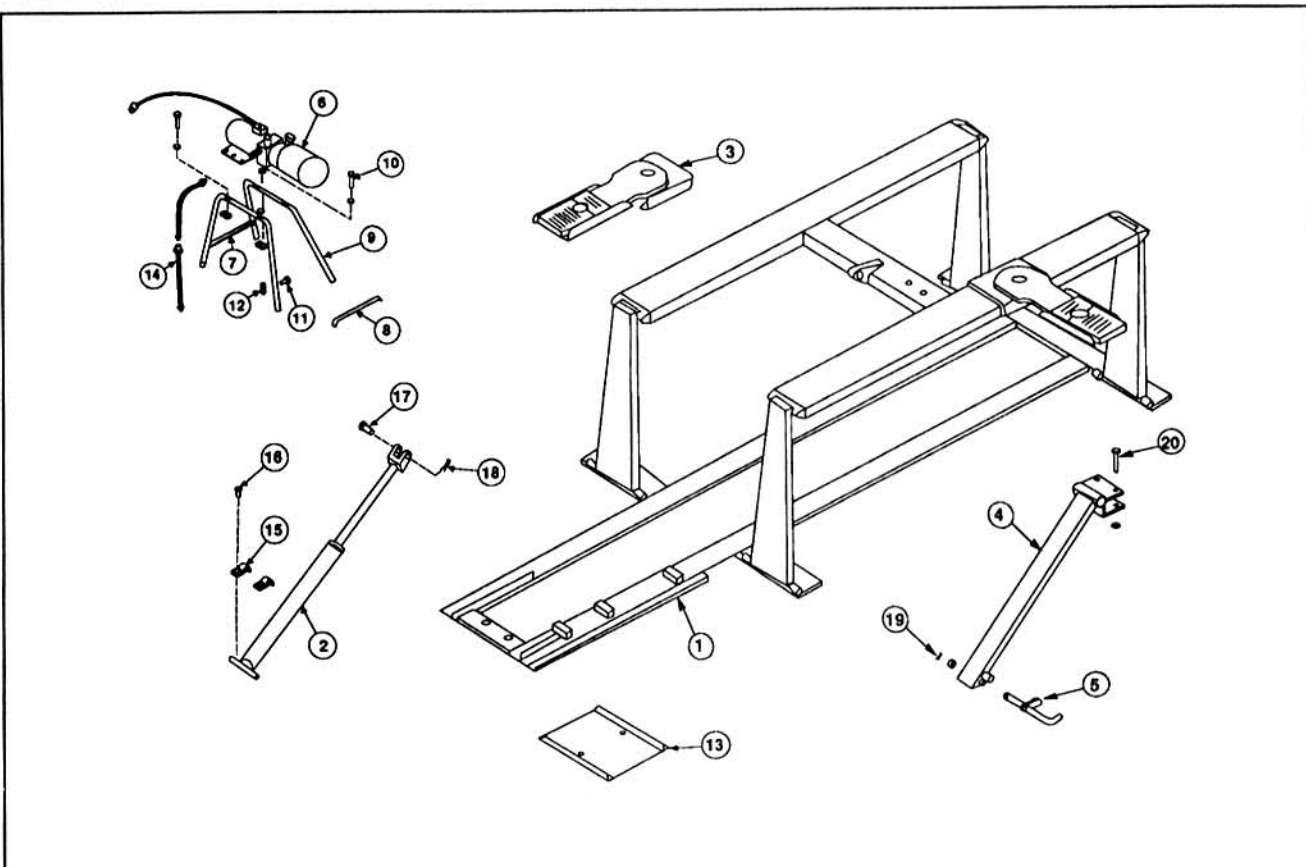

ITEM NO.	DESCRIPTION	PART NO.	ITEM NO.	DESCRIPTION	PART NO.
1	Superstructure	FJ2228	11	1/4"-20NC HHCS x 1" Lg.	(4) Req'd
2	Hydraulic Cylinder	FJ294-3	12	1/4"-20NC Unistrut Nut	(8) Req'd
3	Swivel Arm Assembly	FJ685	13	Wheel Spotting Dish	FF729
4	Automatic Locking Leg	FA2202	14	Hose	FJ801
5	Handle	FA2202-2	15	Cylinder Clip	FJ294-4
6	Power Unit	P501	16	1/2"-13NC x 1" Lg. HHCS	(2) Req'd
7	Complete Power Unit Stand	FA566	17	Clevis Pin	FJ294-3-1
8	Bracket	FA566-1	18	Cotter Pin (3/16" x 1 1/2" Lg.)	
9	Leg	FA566-2	19	Cotter Pin (1/8" x 1" Lg.)	
10	1/4"-20NC HHCS x 2" Lg.	(4) Req'd	20	3/8"-16NC x 2 1/2" Lg. HHCS w/Nut	(2) Req'd

**OWNERS RECORD**

Complete information at right and keep in a safe place.

Date Installed     /    /    

Installed In Bay     

Serial #                      P501

Factory Order #   L  

**IMPORTANT:** When ordering parts or requesting service, always give exact model and jack serial number. Model number is shown on nameplate attached to superstructure. Jack serial number is located on side of plunger at point of attachment to superstructure.

**ROTARY LIFT**  
A **DOVER** INDUSTRIES COMPANY

PANZITTA SALES & SERVICE

72 George Avenue

Wilkes-Barre, PA 18705

570-822-6720 800-822-6720

www.panzittasales.com

INDEX 2.4.4