

PANZITTA SALES & SERVICE
72 George Avenue
Wilkes-Barre, PA 18705
570-822-6720 800-822-6720
www.panzittasales.com



**PARTS LIST
FOR
FORE & AFT
ELECTRIC OIL OPERATED
ADJUSTABLE TRUCK LIFT
A-6CM5A
24,000 LB CAPACITY
8,000 LB FRONT PLUNGER
16,000 LB REAR PLUNGER**

A-6CM5A.max

FORWARD PICKUP BASE AND CARRIAGE ASSEMBLY WITH STANDARD CONTROL BOX

PANZITTA SALES & SERVICE
 72 George Avenue
 Wilkes-Barre, PA 18705
 570-822-6720 800-822-6720
www.panzittasales.com

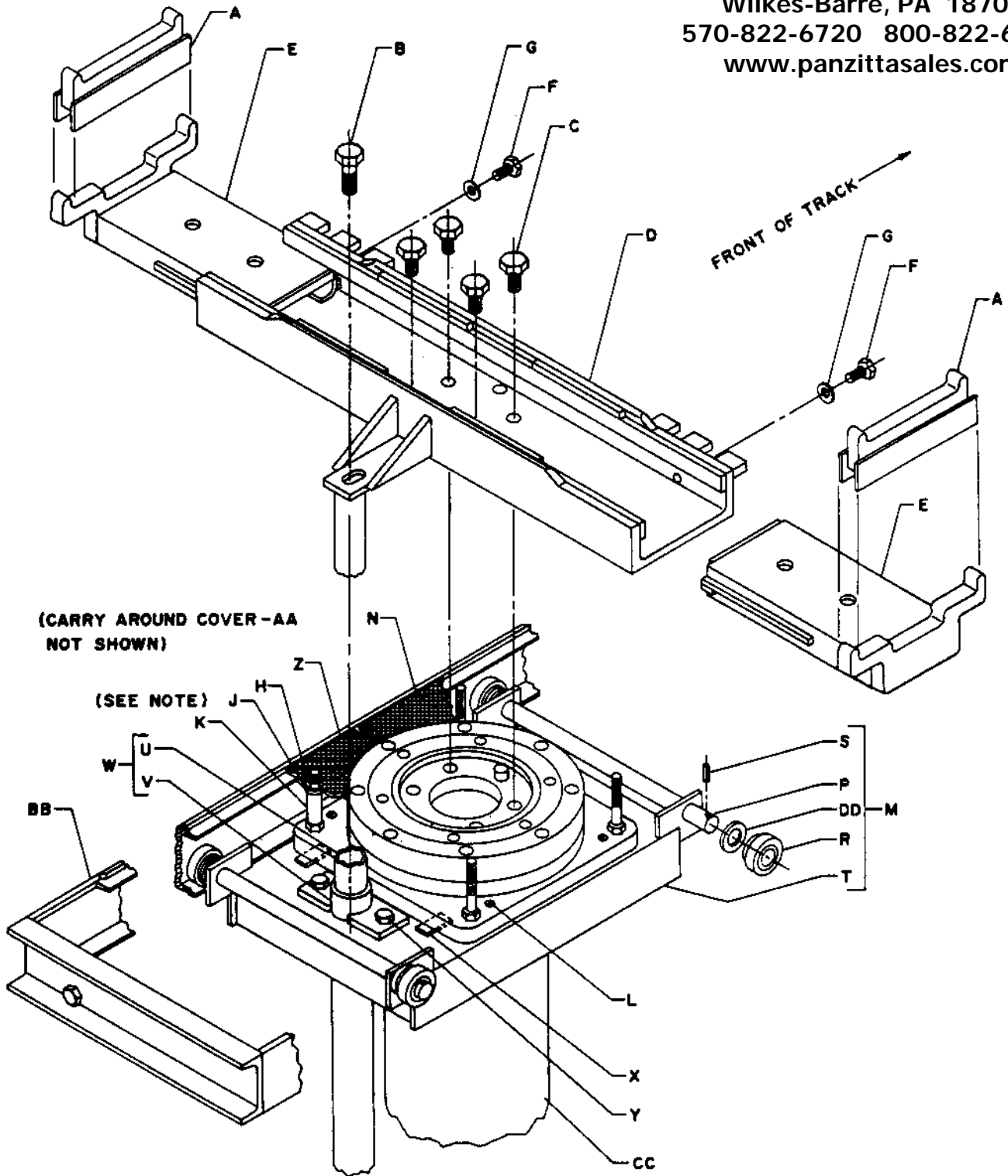

NOTE — WASHER MUST NOT CONTACT COVER
 PLATES OR CARRIAGE WILL NOT MOVE

PANZITTA SALES & SERVICE
72 George Avenue
Wilkes-Barre, PA 18705
570-822-6720 800-822-6720
www.panzittasales.com

**FORWARD PICKUP BASE AND CARRIAGE ASSEMBLY
WITH STANDARD CONTROL BOX PARTS LIST**

Code No.	No. Req.	Symbol No.	Description
A	2	R13424	Height Adapter
B	1	K01914-50	Hex Hd. Bolt 1" -8 x 2-1/2"
C	4	Q10412-01	Hex Hd. Bolt 3/4" -10 x 2-1/4"
D	1	T13930-02	Forward Pickup Base
E	2	R13418	Forward Pickup Slide
F	2	K01902	Hex Hd. Bolt 3/8" -16 x 1"
G	2	K50775	Lockwasher 3/8"
H	8	K01945	Hex Nut 1/2" -13"
J	4	K02208	Washer 1/2"
K	4	K88531-01	Spacer
L	4	K06083-35	Set Screw 1/2" -13 x 1"
M	1	T13924	Carriage Assembly (Includes P, R, S & T)
N	1	R14469-01	Front Trench Cover Assembly
P	2	K88533	Carriage Axle
R	4	K88995	Carriage Wheel Assembly
S	4	K67240	Groove Pin 3/16" Dia. x 1-1/2"
T	1	T13923	Carriage Weldment
U	1	R13470-07	Telescoping Post & Latch Assy.
V	1	N20234-01	Stationary Tube Assembly
W	1	K88961-01	Automatic Lock Assembly (Includes B, U & V)
X	16	K88438	Shim
Y	2	K01909	Hex Hd. Bolt 1/2" -13 x 1"
Z	1	R13415-04	Front Trench Cover Assembly
AA	2	R13355	Trench Cover (10 Ft.)
AA	3	R13355	Trench Cover (12 Ft.)
AA	4	R13355	Trench Cover (14 Ft.)
AA	5	R13355	Trench Cover (16 Ft.)
BB	1	T13918-01	Track Assembly (10 Ft.)
BB	1	T13918-02	Track Assembly (12 Ft.)
BB	1	T13918-03	Track Assembly (14 Ft.)
BB	1	T13918-04	Track Assembly (16 Ft.)
CC	1	T13922-01	Plunger & Cylinder Assembly (See Page 17)
DD	4	K88459	Washer

A-6CM5A.max

FORWARD PICKUP BASE AND CARRIAGE ASSEMBLY WITH EXTENDED CONTROL BOX (OPTIONAL)

PANZITTA SALES & SERVICE
 72 George Avenue
 Wilkes-Barre, PA 18705
 570-822-6720 800-822-6720
 www.panzittasales.com

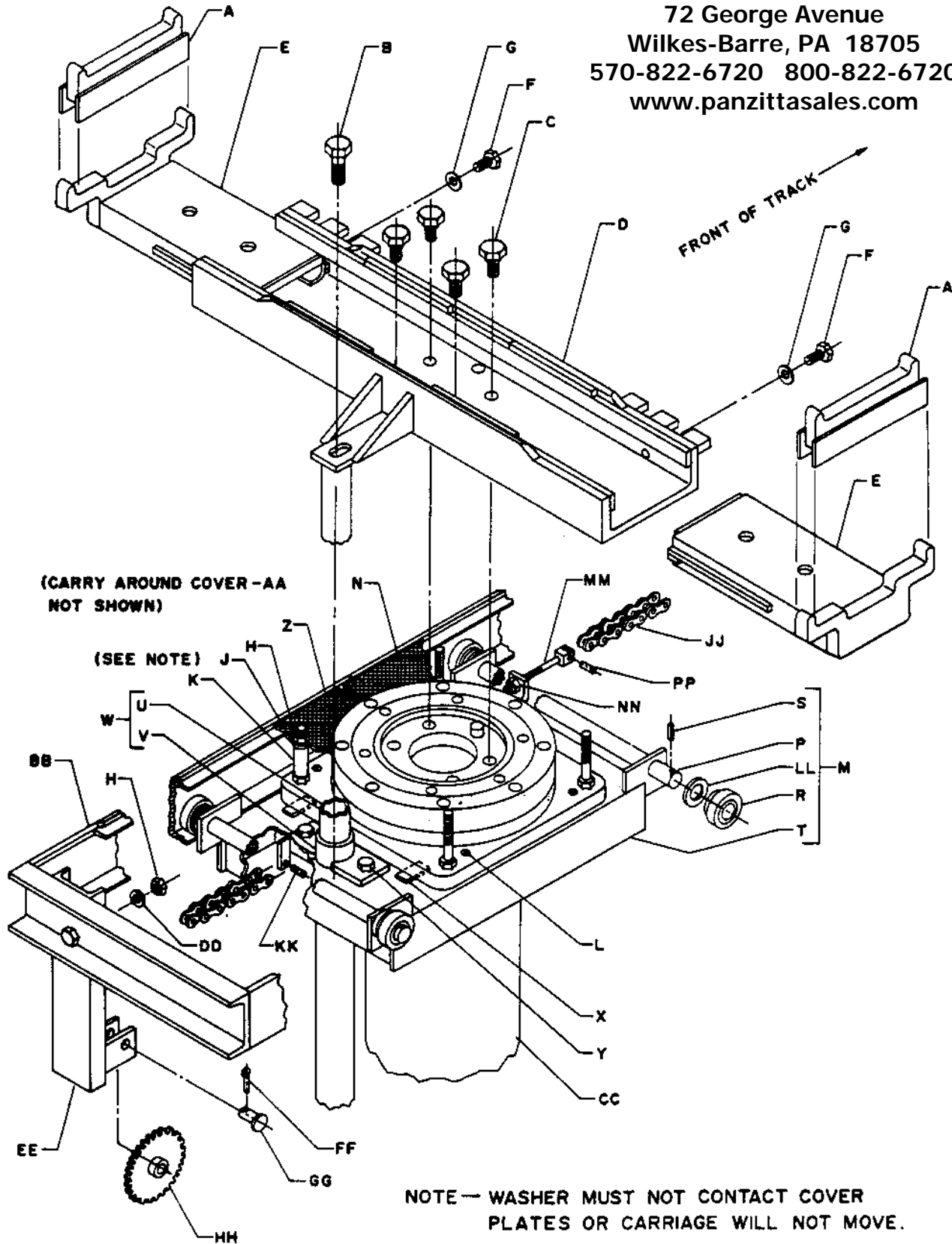

T13972

Fig. 6

IMPORTANT: Specify Model and Serial Number of Lift. Also Symbol Number and Name of Part.

PANZITTA SALES & SERVICE
72 George Avenue
Wilkes-Barre, PA 18705
570-822-6720 800-822-6720
www.panzittasales.com

FORWARD PICKUP BASE AND CARRIAGE ASSEMBLY
WITH EXTENDED CONTROL BOX PARTS LIST (OPTIONAL)

Code No.	No. Req.	Symbol No.	Description
A	2	R13424	Height Adapter
B	1	K01914-50	Hex Hd. Bolt 1" -8 x 2-1/2"
C	4	Q10412-01	Hex Hd. Bolt 3/4" -10 x 2-1/4"
D	1	T13930-02	Forward Pickup Base
E	2	R13418	Forward Pickup Slide
F	2	K01902	Hex Hd. Bolt 3/8" -16 x 1"
G	2	K50775	Lockwasher 3/8"
H	10	K01945	Hex Nut 1/2" -13"
J	4	K02208	Washer 1/2"
K	4	K88531-01	Spacer
L	4	K06083-35	Set Screw 1/2" -13 x 1"
M	1	T13924	Carriage Assembly (Includes P, R, S & T)
N	1	R13415-03	Front Trench Cover Assembly
P	2	K88533	Carriage Axle
R	4	K88995	Carriage Wheel Assembly
S	4	K67240	Groove Pin 3/16" Dia. x 1-1/2"
T	1	T13923	Carriage Weldment
U	1	R13470-07	Telescoping Post & Latch Assembly
V	1	N20234-01	Stationary Tube Assembly
W	1	K88961-01	Automatic Lock Assembly (Included B, U & V)
X	16	K88438	Shim
Y	2	K01909	Hex Hd. Bolt 1/2" -13 x 1"
Z	1	R13415-04	Front Trench Cover Assembly
AA	2	R13179	Trench Cover (10 Ft.)
AA	3	R13179	Trench Cover (12 Ft.)
AA	4	R13179	Trench Cover (14 Ft.)
AA	5	R13179	Trench Cover (16 Ft.)
BB	1	T13918-01	Track Assembly (10 Ft.)
BB	1	T13918-02	Track Assembly (12 Ft.)
BB	1	T13918-03	Track Assembly (14 Ft.)
BB	1	T13918-04	Track Assembly (16 Ft.)
CC	1	T13922-01	Plunger & Cylinder Assembly (See Page 17)
DD	2	K02455	Lockwasher 1/2"
EE	1	N21712-01	Sprocket Support
FF	1	K02128	Cotter Pin 1/8" Dia. x 1"
GG	1	Q10167-13	Clevis Pin 5/8" Dia. x 1-3/4"
HH	1	K90624	Sprocket
JJ	1	K89040-17	Chain (10 Ft.)
JJ	1	K89040-18	Chain (12 Ft.)
JJ	1	K89040-19	Chain (14 Ft.)
JJ	1	K89040-20	Chain (16 Ft.)
KK	1	K78378-39	Roll Pin 3/16" Dia. x 1-3/8"
LL	4	K89459	Washer
MM	1	K90604	Anchor Rod Assembly
NN	1	Q10977-03	Locknut 5/16" -18
PP	1	K78378-48	Roll Pin 5/32" Dia. x 3/4"

STANDARD CONTROL BOX AND RATCHET CUP

PANZITTA SALES & SERVICE
 72 George Avenue
 Wilkes-Barre, PA 18705
 570-822-6720 800-822-6720
 www.panzittasales.com

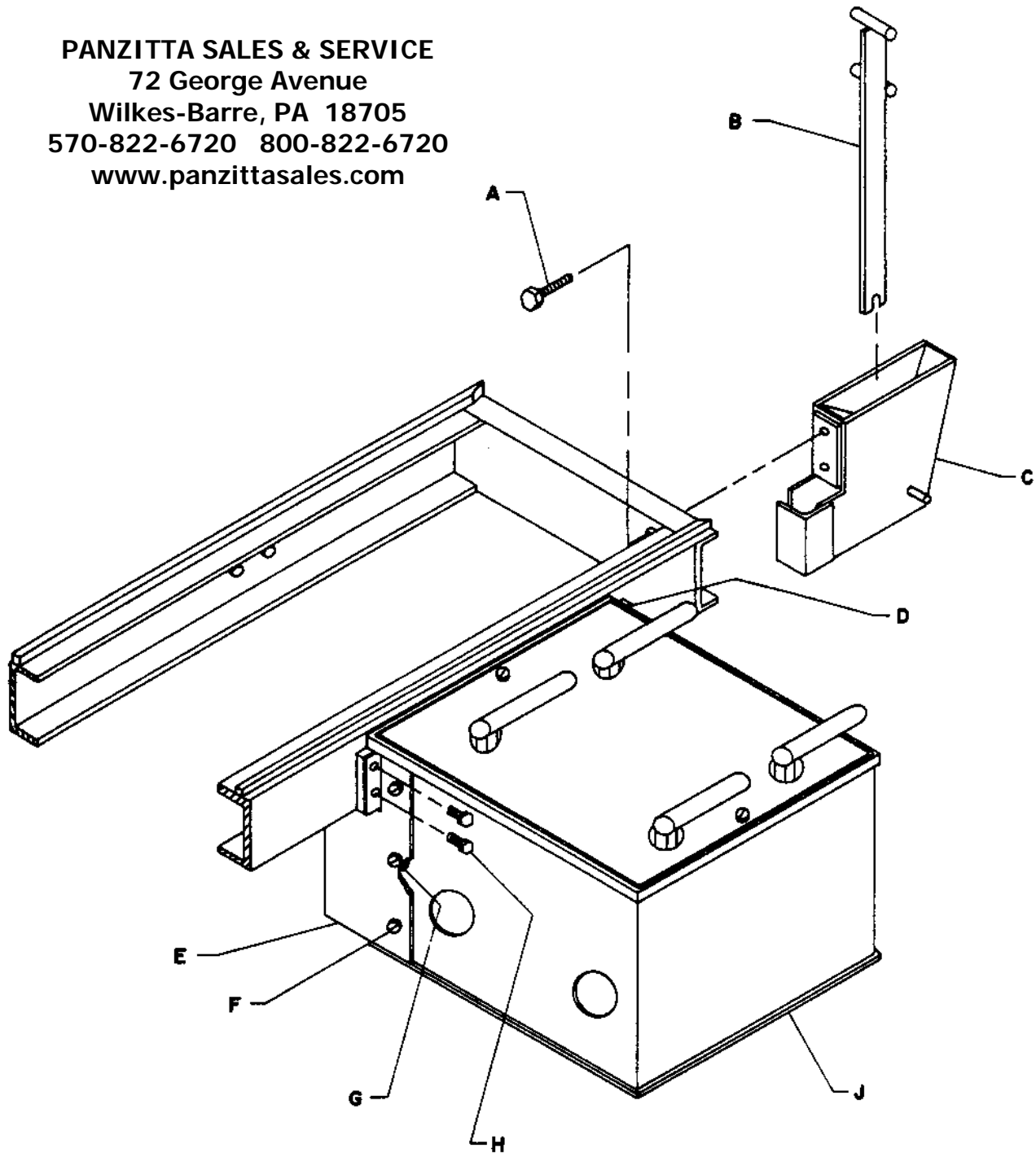

T11902

Fig. 7

Code	No. Req.	Symbol No.	Description
A	2	K03782	Hex. Hd. Bolt 5/16"-18 x 1-3/4"
B	1	N20309	Lever Assembly
C	1	R14470	Ratchet Cup
D	1	R13489-01	Mounting Bracket (R. H.)
E	1	R13489-02	Mounting Bracket (L. H.)
F	6	K60521-24	Self Tapping Screw #14 - 5/8"
G	6	K66871	Flat Washer
H	4	K05287	Hex Hd. Bolt 1/4"-20 x 1/2"
J	1	T09513	Control Box Assembly (See page 16)

IMPORTANT: Specify Model and Serial Number of Lift. Also Symbol Number and Name of Part.

EXTENDED CONTROL BOX

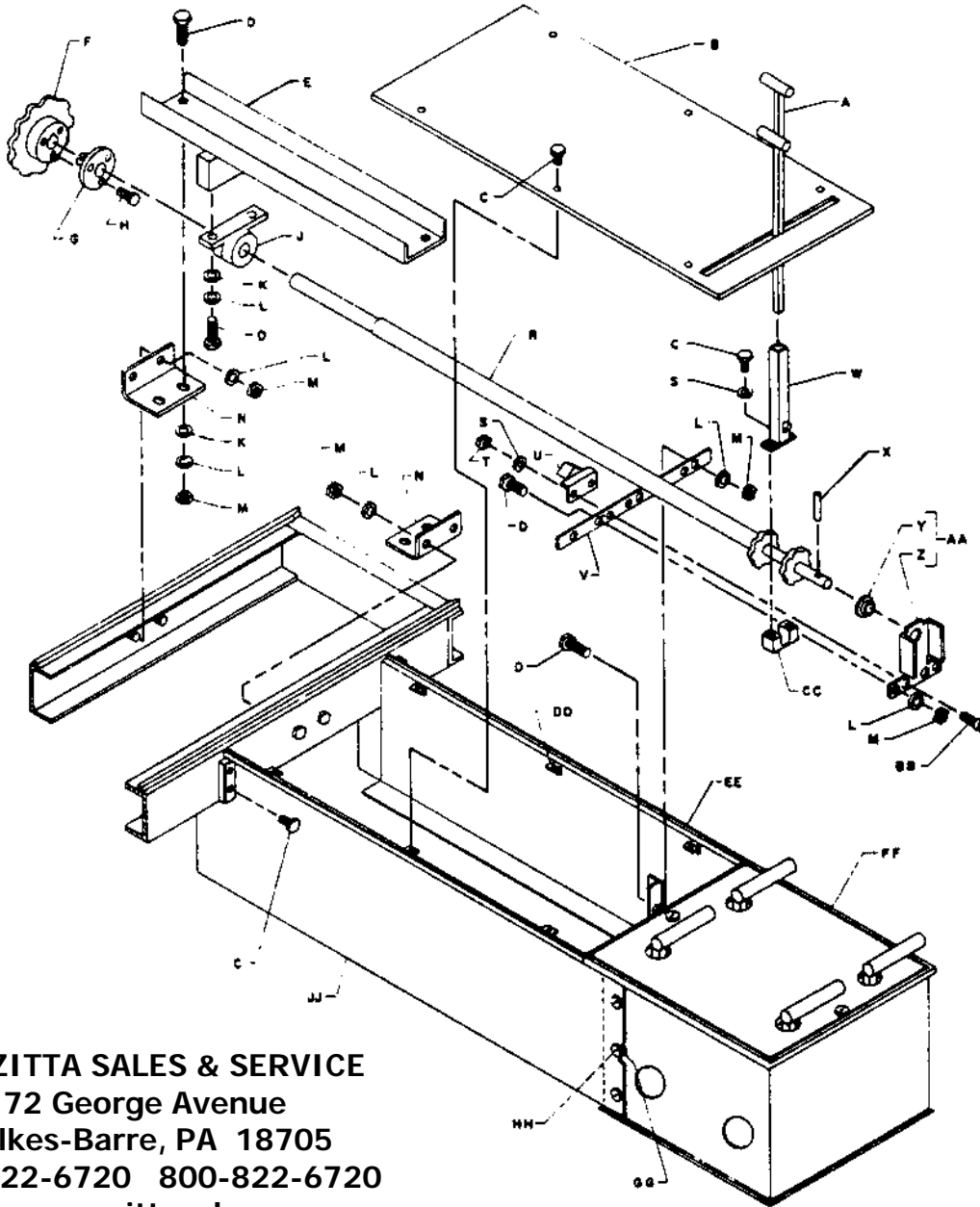

PANZITTA SALES & SERVICE
 72 George Avenue
 Wilkes-Barre, PA 18705
 570-822-6720 800-822-6720
 www.panzittasales.com

T13968

Fig. 8

Code No.	No. Req.	Symbol No.	Description	Code No.	No. Req.	Symbol No.	Description
A	1	R16171-01	Ratchet Handle	U	1	K90607	Stop Weldment
B	1	T13872-01	Extension Box Cover	V	1	N21460	Ratchet Support Bar
C	12	K05287	Hex Hd. Bolt 1/4" -20 x 1/2"	W	1	N21714	Handle Holder Assembly
D	10	K01902	Hex Hd. Bolt 3/8" -16 x 1"	X	1	K78378-39	Roll Pin 3/16" Dia. x 1-3/8"
E	1	N21456-01	Bearing Mounting Bracket	Y	1	N17706-40	Flanged Bearing
F	1	K90615	Sprocket	Z	1	N21474	Ratchet Support Weldment
G	1	K90616	Split Taper Bushing	AA	1	N21470	Ratchet Support Assembly (Includes Y & Z)
H	3	K07565	Hex Hd. Bolt 5/16" -18 x 1"	BB	2	Q10033-69	Socket Hd. Cap Screw 1/4" -20 x 3/4"
J	1	K90618	Pillow Block	CC	1	K90609	Pivot Block
K	6	K02206	Flat Washer 3/8"	DD	6	K81038-24	Speed Nut 1/4" -20
L	14	K50775	Lockwasher 3/8"	EE	1	T09499-05	Side Panel Weldment (R.H.)
M	12	K01943	Hex Nut 3/8" -16	FF	1	T09513	Control Box Assembly (See Page 16)
N	2	N21769	Support Bracket	GG	6	K66871	Flat Washer
R	1	N21717-02	Sprocket Shaft Assembly	HH	6	K60521-24	Self Tapping Screw #14 x 5/8"
S	4	K43948	Lockwasher 1/4"	JJ	1	T09499-06	Side Panel Weldment (L.H.)
T	2	K01941	Hex Nut 1/4" -20				

IMPORTANT: Specify Model and Serial Number of Lift. Also Symbol Number and Name of Part.

REAR TRENCH BOX AND AXLE SUPPORTS

PANZITTA SALES & SERVICE
 72 George Avenue
 Wilkes-Barre, PA 18705
 570-822-6720 800-822-6720
 www.panzittasales.com

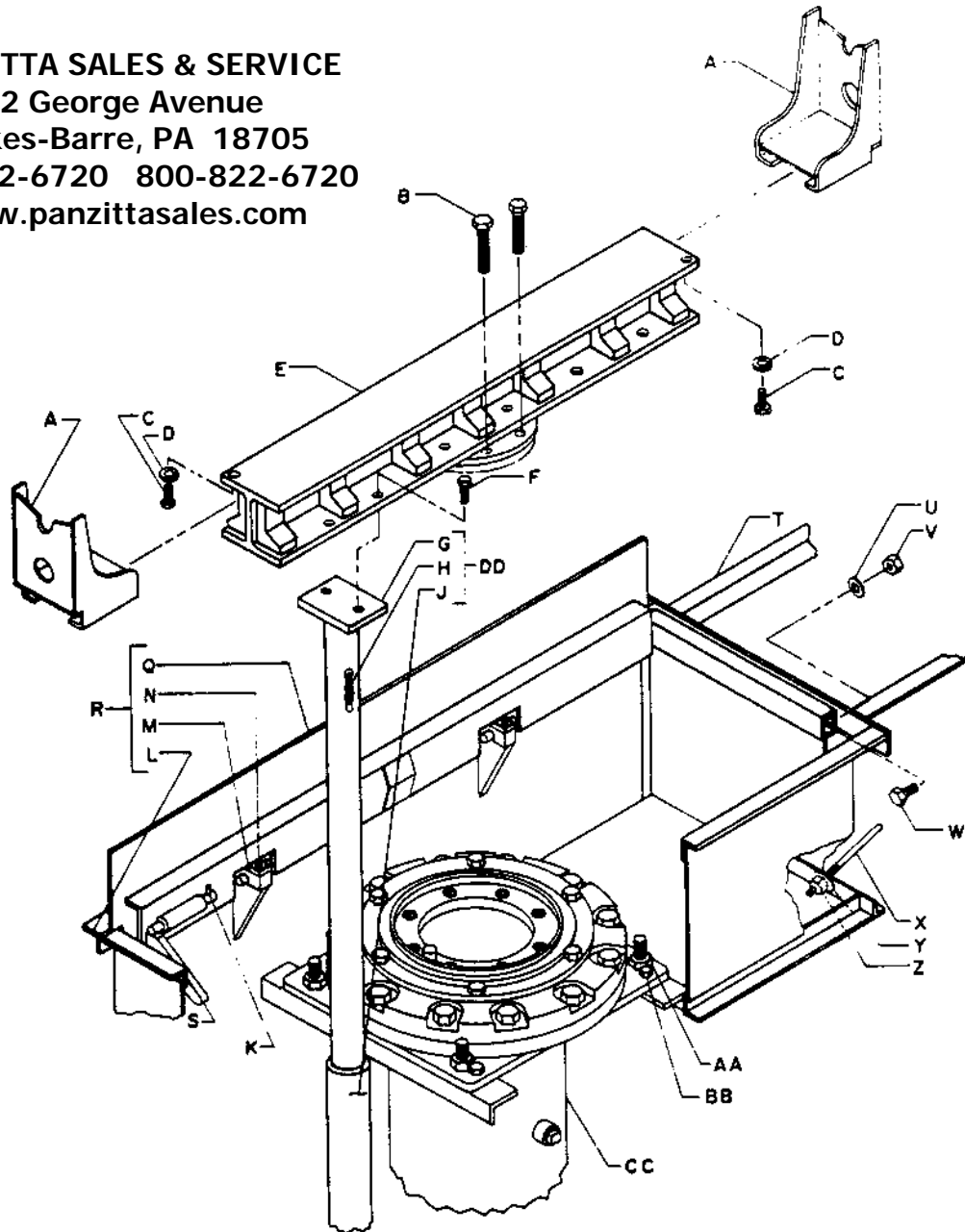

R16288

Fig. 9

Code No.	No. Req.	Symbol No.	Description	Code No.	No. Req.	Symbol No.	Description
A	2	R13488	Axle Support	R	1	T13955	Rear Box & Door Assembly (includes L, M, N & Q)
B	8	Q10412-01	Hex Hd. Bolt 3/4" -10 x 2-1/4"	S	2	K88445-01	Door Closer
C	2	K51954	Hex Hd. Bolt 3/8" -16 x 1/2"	T	2	R14588	Wheel Locator
D	2	K50775	Lockwasher 3/8"	U	4	K86314	Flat Washer 3/8"
E	1	T13934	Axle Support Beam	V	4	K01943	Hex Nut 3/8" -16
F	2	K01914-61	Hex Hd. Bolt 3/4" -10 x 1-1/4"	W	4	K01901	Hex Hd. Bolt 3/8" -16 x 3/4"
G	1	T11967-01	Telescoping Post & Latch Assembly	X	4	K89033	Anchor Rod
H	1	K89525	Spring	Y	16	K02204	Flat Washer 1/4"
J	1	N20215-02	Stationary Tube Assembly	Z	16	K01941	Hex Nut 1/4" -20
K	2	K78375-48	Roll Pin 5/32" Dia. x 3/4"	AA	4	K01948	Hex Nut 3/4" -10
L	1	T13954	Trench Box Weldment	BB	4	K01914-40	Hex Hd. Bolt 1/2" -13 x 2-1/2"
M	4	K88461	Top Hinge	CC	1	T13945-01	Plunger & Cylinder Assembly (See Page 18)
N	8	Q10098-48	Flat Hd. Socket Screw 3/8" -16 x 3/4"	DD	1	K89528-01	Automatic Lock Assy. (Includes G, H & J)
Q	1	T13941	Rear Box Door				

IMPORTANT: Specify Model and Serial Number of Lift. Also Symbol Number and Name of Part.

CONTROL BOX ASSEMBLY

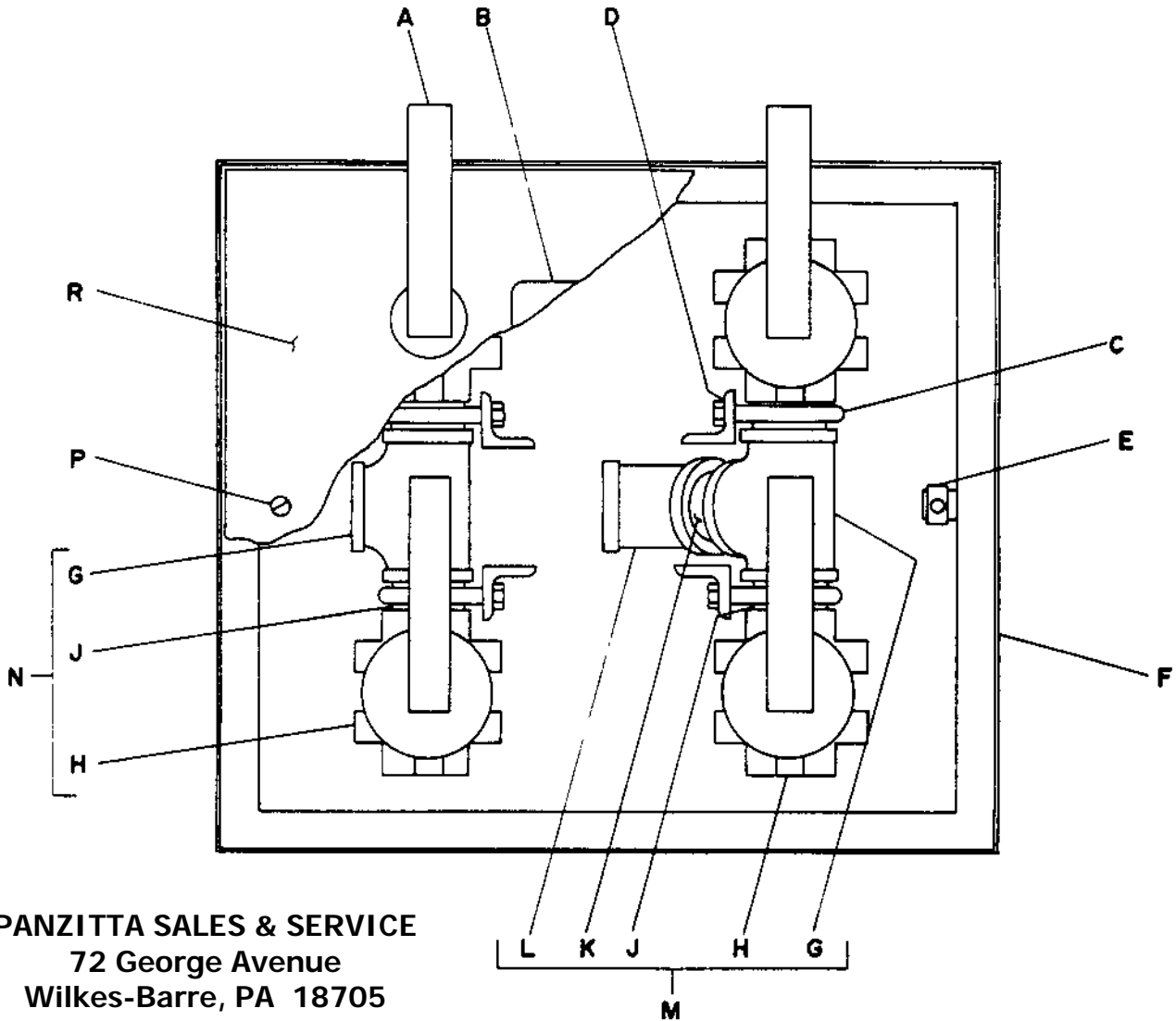

PANZITTA SALES & SERVICE
 72 George Avenue
 Wilkes-Barre, PA 18705
 570-822-6720 800-822-6720
 www.panzittasales.com

SEE PAGES 13 & 14 FOR CONTROL BOX LOCATION

R14468

Code	No. Req.	Symbol No.	Description
A	4	N19602	Oil Control Handle
B	1	N21383	Indicator Plate
C	4	K13758	U-Bolt 1/4"
D	8	K01941	Hex Nut 1/4"-20
E	2	K81038-24	Speed Nut 1/4"-20
F	1	T09511	Control Box
G	2	K02309A01	Tee 1-1/4"
H	4	R14467	Oil Valve (see page 23, Fig. 1)
J	4	R11494-51	Nipple 1-1/4" x 1-5/8"

Code	No. Req.	Symbol No.	Description
K	1	R11494-20	Nipple 1-1/4" x 2-1/4"
L	1	K03608-24	Elbow 1-1/4" x 45°
M	1	R13500	Oil Valve & Tee Assembly (includes G, H, J, K & L)
N	1	R13499	Oil Valve & Tee Assembly (includes G, H & J)
P	2	K11061	Round Hd. Screw 1/4"-20 x 5/8"
R	1	R14466	Cover

IMPORTANT: Specify Model and Serial Number of Lift. Also Symbol Number and Name of Part.

PLUNGER AND CYLINDER ASSEMBLY (FRONT)

Code No.	No. Req.	Symbol No.	Description
A	1	T13922-01	Plunger & Cylinder Assy.
B	1	T13919-G1	Cylinder Assembly
C	1	T13912-G2	Plunger Assembly
D	2	T13911-02	Upper Bearing
E	2	K93210-02	Felt Wiper
F	16	Q10034-82	Soc. Hd. Bolt 1/2" -13 x 2"
G	2	T13915-01	Wiper Retainer
H	12	Q10034-28	Soc. Hd. Bolt 3/8" -16 x 3/4"
J	2	N21812-G1	Air Vent
K	2	K93211	Wiper
L	2	K92328	Seal
M	2	Q10069-30	O-Ring
	2	K34152	Seal Kit (Includes D,J,K&L)

PANZITTA SALES & SERVICE
 72 George Avenue
 Wilkes-Barre, PA 18705
 570-822-6720 800-822-6720
 www.panzittasales.com

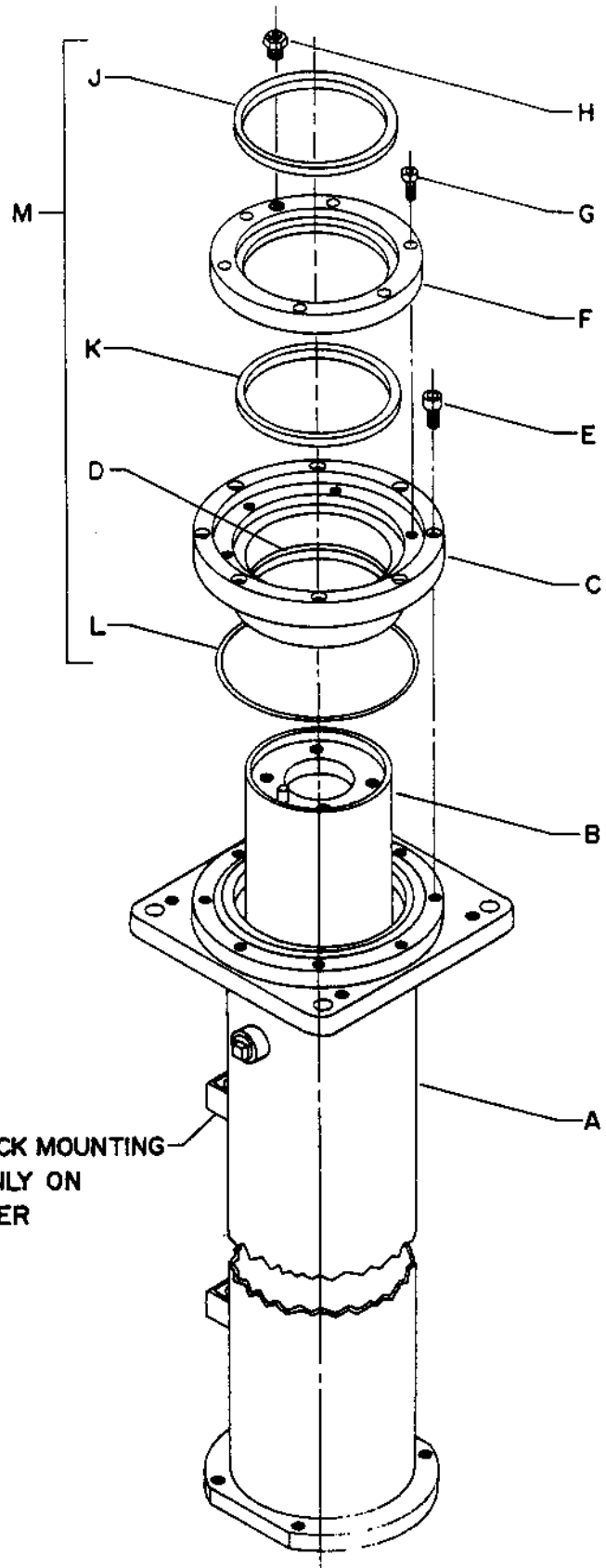

*WHEN ORDERING PLUNGER ASSY. OR CYLINDER ASSY. SPECIFY SYMBOL NO. ALSO CODE LETTER STAMPED ON TOP OF PLUNGER.

AUTOMATIC LOCK MOUNTING BRACKETS ONLY ON REAR CYLINDER

R16283

IMPORTANT: Specify Model and Serial Number of Lift. Also Symbol Number and Name of Part.

PLUNGER AND CYLINDER ASSEMBLY (REAR)

Code No.	No. Req.	Symbol No.	Description
A	1	T13945-01	Plunger & Cylinder Assembly
B	1	T13939-G1	Cylinder Assembly
C	1	T13935-G1	Plunger Assembly
D	1	T13943-02	Upper Bearing
E	1	K93210-01	Felt Wiper
F	12	Q10412-01	Hex Hd. Bolt 3/4" -10 x 2-1/4"
G	1	R18229	Wiper Retainer
H	6	K01907	Hex Hd. Bolt 7/16" -14 x 1-1/2"
J	1	K93212	Wiper
K	1	K89512	Seal
L	1	K93213-01	O-Ring
M	1	K34151	Seal Kit (Includes D,H,J&K)
	1	N21812-G1	Air Vent

PANZITTA SALES & SERVICE
 72 George Avenue
 Wilkes-Barre, PA 18705
 570-822-6720 800-822-6720
 www.panzittasales.com

*WHEN ORDERING PLUNGER ASSY.
 SPECIFY SYMBOL NO. AND CODE
 LETTER
 STAMPED ON TOP OF PLUNGER.

AUTOMATIC LOCK MOUNTING
 BRACKETS ONLY ON
 REAR CYLINDER

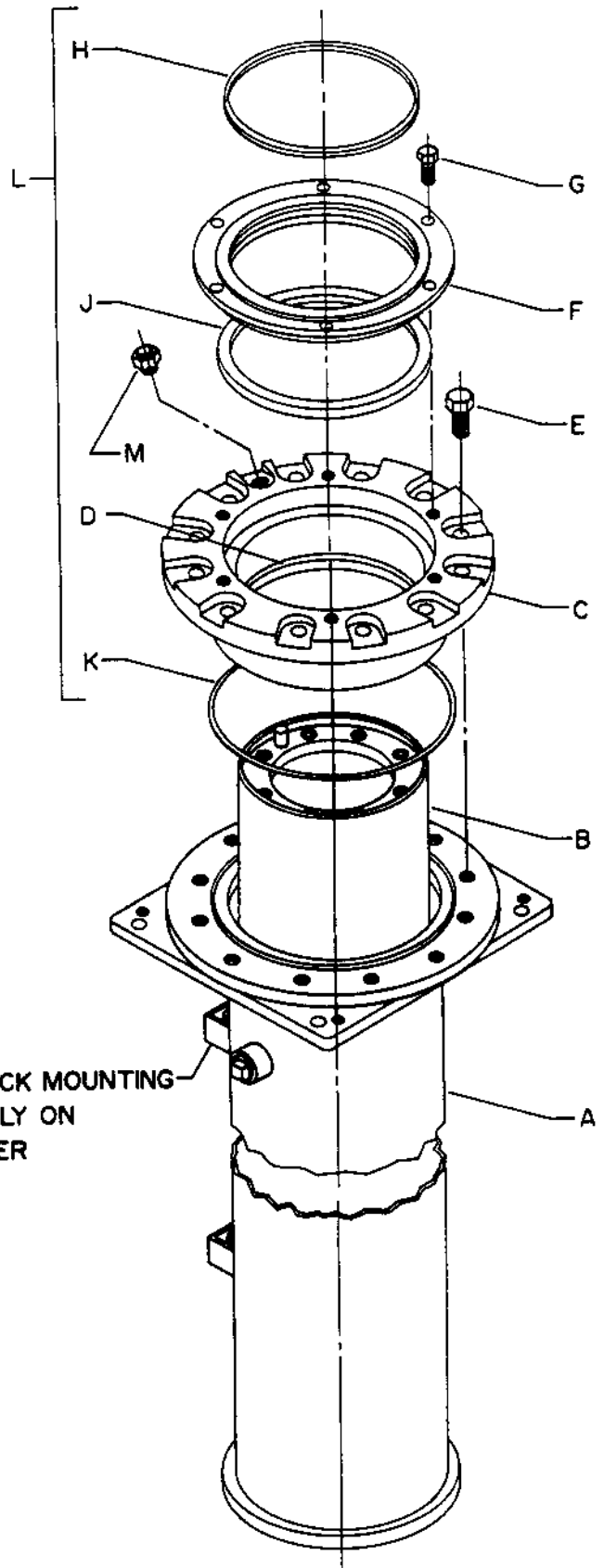

R16287

IMPORTANT: Specify Model and Serial Number of Lift. Also Symbol Number and Name of Part.

**ELECTRIC OIL POWER UNIT FOR MODELS
AHE 010102 THRU AHE 030102
(WITH COMM. SHEARING PUMP)**

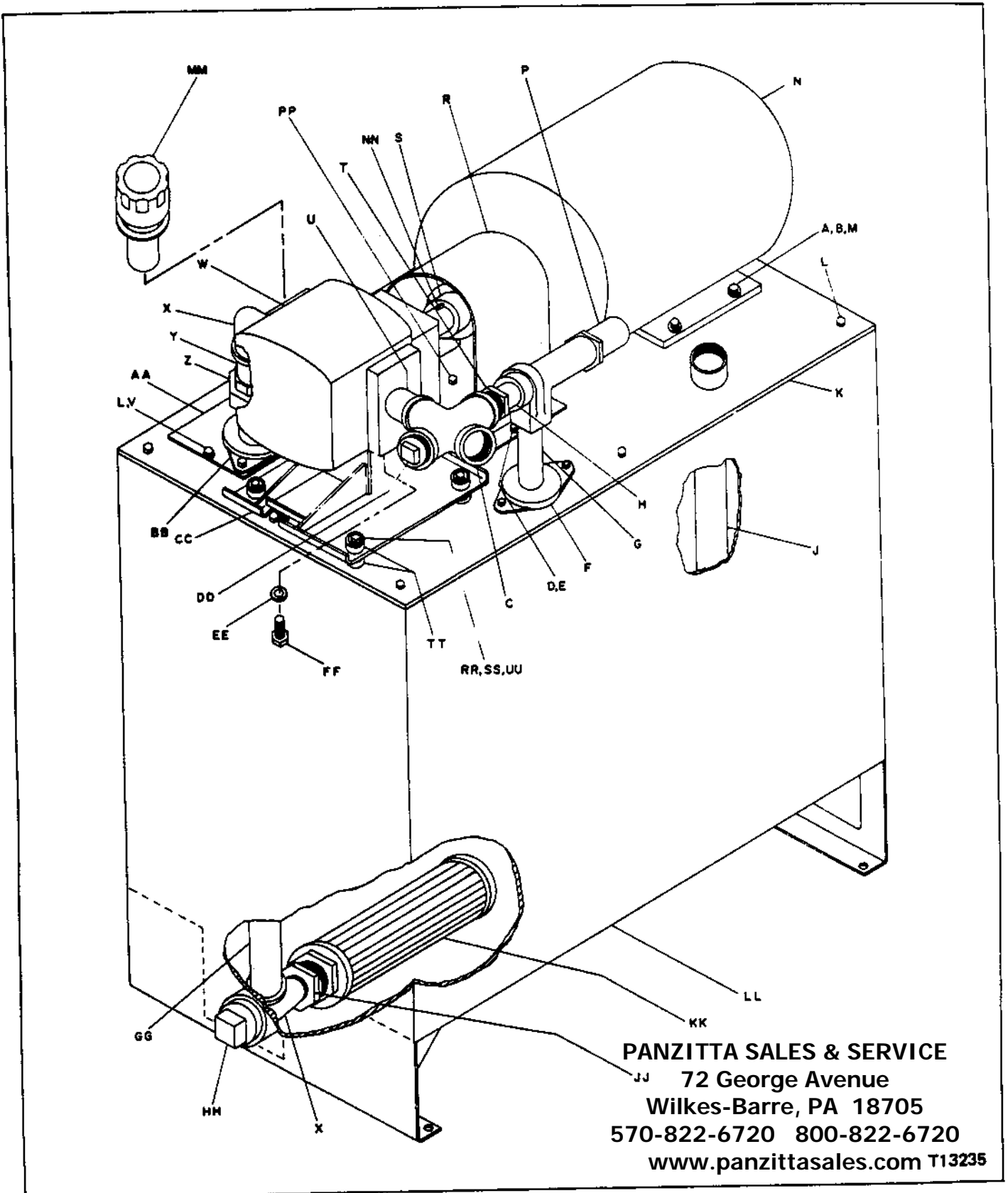

PANZITTA SALES & SERVICE
 72 George Avenue
 Wilkes-Barre, PA 18705
 570-822-6720 800-822-6720
 www.panzittasales.com T13235

IMPORTANT: Specify Model and Serial Number of Lift. Also Symbol Number and Name of Part.

PANZITTA SALES & SERVICE
72 George Avenue
Wilkes-Barre, PA 18705
570-822-6720 800-822-6720
www.panzittasales.com

ELECTRIC OIL POWER UNIT FOR MODELS
AHE 010102 THRU AHE 030102 PARTS
(WITH COMM. SHEARING PUMP)

Code No.	No. Req.	Symbol No.	Description
A	4	K01903	Hex Hd. Bolt 3/8 -16 x 1-1/4"
B	4	K50775	Lockwasher 3/8"
C	1	K06776-01	Cross 1-1/4"
D	2	K05287	Hex Hd. Bolt 1/4 -20 x 1/2"
E	2	K50773	Lockwasher 1/4"
F	1	N21737-01	Suction Flange
G	1	K89450	Relief Pipe 1"
H	1	K07816	Nipple 1" x 2-1/2"
J	1	K89451	Return Pipe 1-1/4"
K	1	R14504-01	Tank Cover (60 Gal.)
K	1	R14504-03	Tank Cover (170 Gal.)
L	10	K60521-24	Hex Hd. Self Tapping Screw #14 x 5/8"
M	4	K02206	Flat Washer 3/8"
N	1	T08833-77	Motor 7 1/2 HP, 230/460V, 60 CY, 3 PH
N	1	T08833-78	Motor 7 1/2 HP, 200V, 60 CY, 3 PH
N	1	T08833-83	Motor 7 1/2 HP, 230V, 60 CY, 1 PH
P	1	N20302-01	Relief Valve (For Replacement Parts See Page 21)
R	1	R14502	Coupling Guard
S	1	N20382-01	Coupling (For Replacement Parts, See Page 22)
T	1	Q10837-10	Hex Reducing Bushing 1-1/4" to 1"
U	1	R11494-24	Nipple 1-1/4" x 2-1/2"
V	2	K66871	Flat Washer
W	1	K89445	Gear Pump
X	2	K62381	Street Elbow 1-1/4" x 90°
Y	1	R11494-25	Nipple 1-1/4" x 2"
Z	1	K12176	Union 1-1/4"
AA	1	N20344	Filter Cover
BB	1	N21737-02	Suction Flange
CC	1	R16116	Pump Mounting Plate
DD	1	K02309C02	Pipe Plug 1-1/4"
EE	4	K02455	Lockwasher 1/2"
FF	4	K01909	Hex Hd. Bolt 1/2 -13 x 1"
GG	1	R11532-73	Suction Pipe 1-1/4" x 31"
HH	1	K02286	Pipe Plug 2"
JJ	1	K61580	Hex Reducing Bushing 2" to 1-1/4"
KK	1	K89036	Suction Element
LL	1	T11927-01	Tank (60 Gal.)
LL	1	T11927-03	Tank (170 Gal.)
MM	1	N20383	Air Breather (Twist Type)
NN	1	K89553	Pump Step Key
PP	1	K05350	Hex Hd. Bolt 3/8" -16 x 2-1/4"
RR	4	K03239	Hex Hd. Bolt 5/16" -18 x 1-1/2"
SS	4	K83676	Spacer
TT	4	K83674	Rubber Mount
UU	4	N16599-35	Washer

RELIEF VALVE

PANZITTA SALES & SERVICE
 72 George Avenue
 Wilkes-Barre, PA 18705
 570-822-6720 800-822-6720
 www.panzittasales.com

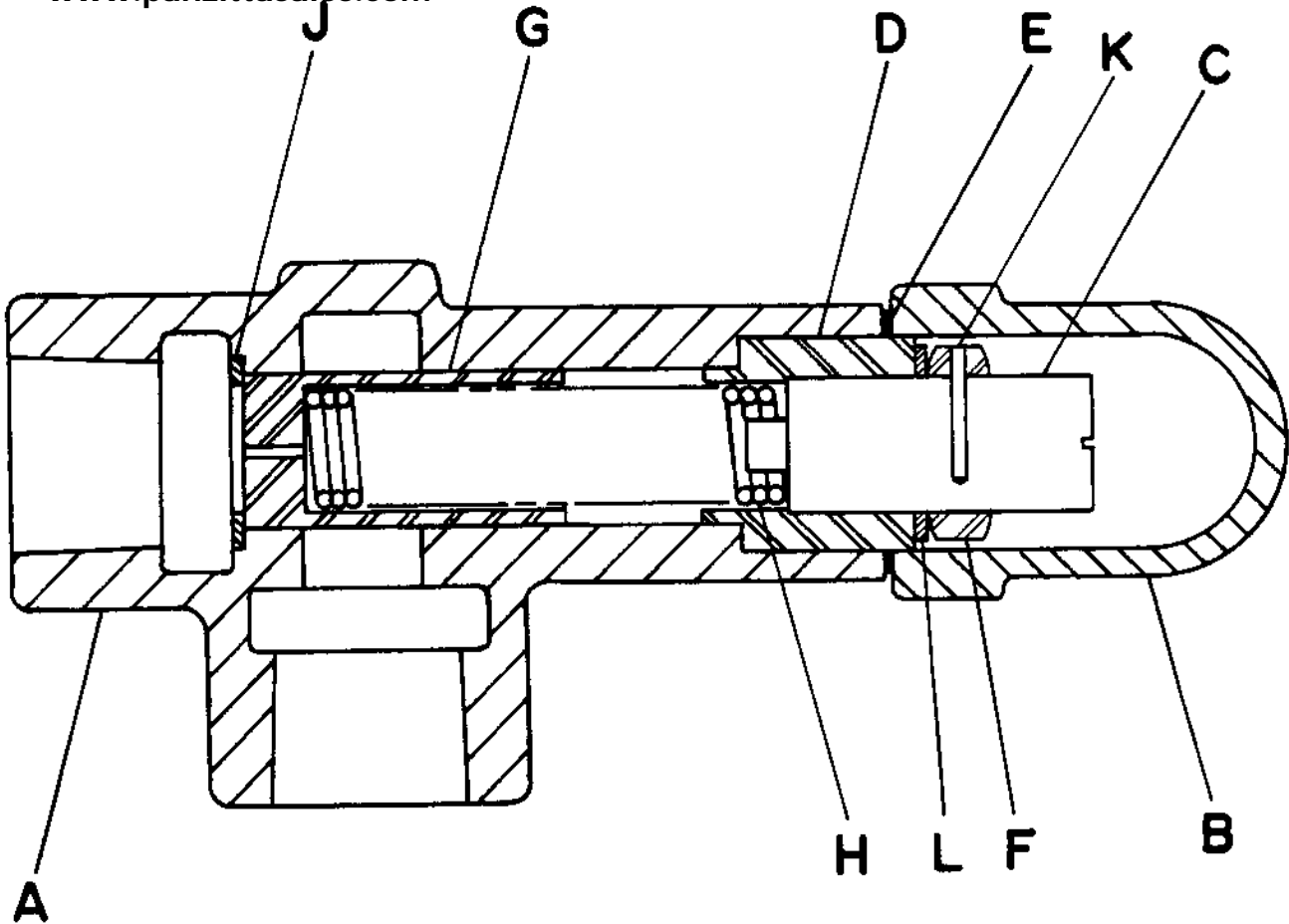

N20342

Code No.	No. Req.	Symbol No.	Description
A	1	N20302-02	Body
B	1	N20302-03	Cap
C	1	N20302-04	Adjusting Screw
D	1	N20302-05	Retainer
E	1	N20302-06	Gasket
F	1	N20302-07	Locknut
G	1	N20302-08	Piston
H	1	N20302-09	Spring
J	1	N20302-10	Stop Ring
K	1	K48864	Groove Pin
L	1	N16599-72	Flat Washer

COUPLING

PANZITTA SALES & SERVICE
 72 George Avenue
 Wilkes-Barre, PA 18705
 570-822-6720 800-822-6720
 www.panzittasales.com

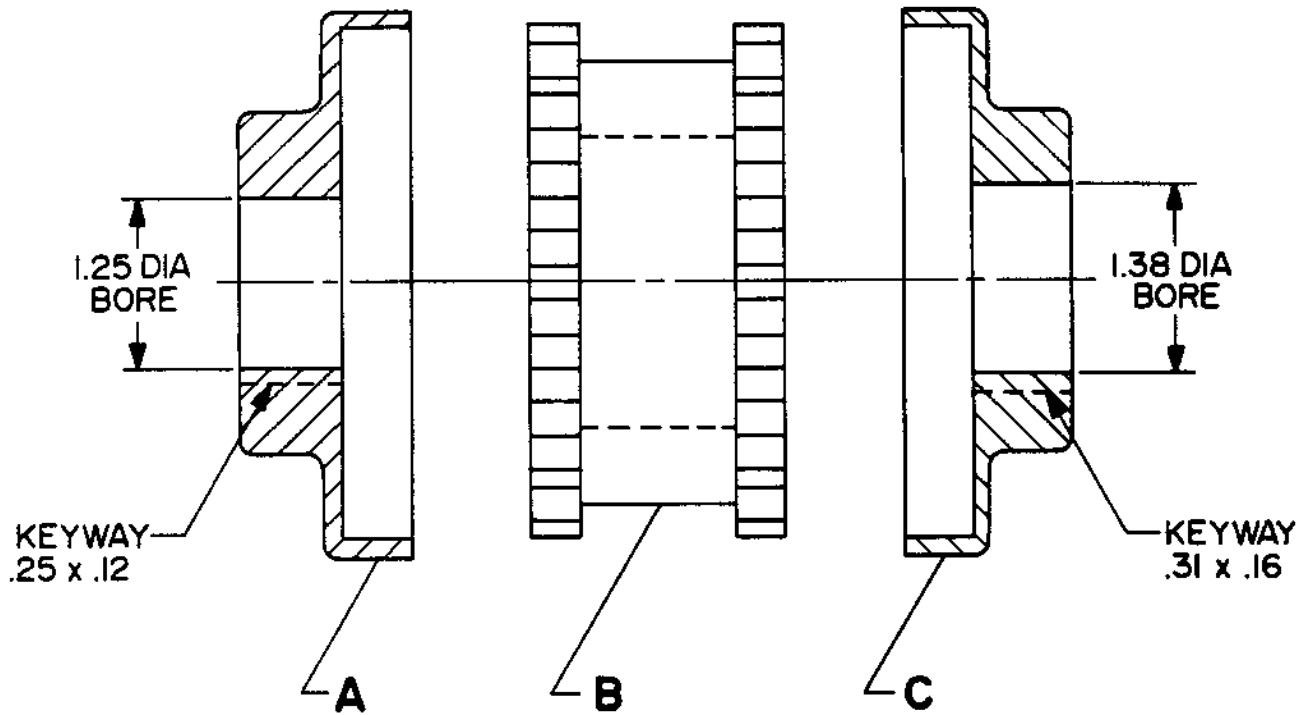

N20388

Code No.	No. Req.	Symbol No.	Description
A	1	N20382-03	Flange 1-1/4" Bore
B	1	N20382-02	Sleeve
C	1	N20382-04	Flange 1-3/8" Bore

OIL VALVE

PANZITTA SALES & SERVICE
 72 George Avenue
 Wilkes-Barre, PA 18705
 570-822-6720 800-822-6720
 www.panzittasales.com

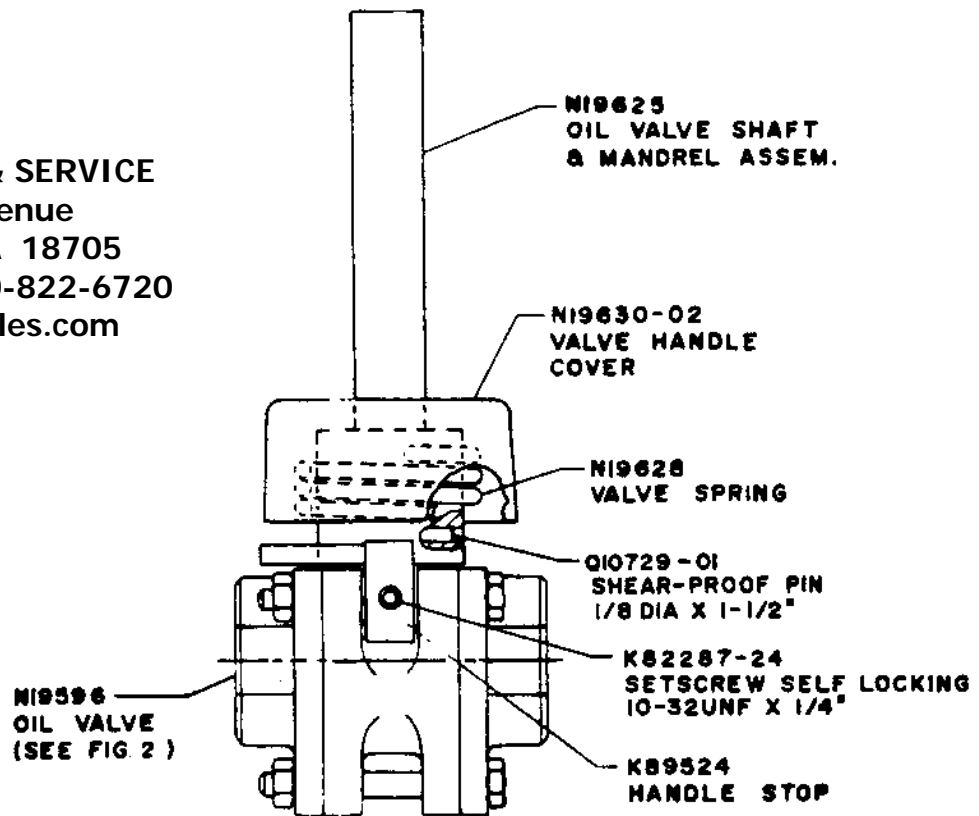

FLOOR CONTROL
 COMPLETE OIL VALVE
 ASSEMBLY R14467

FIG 1

NOTE: THE OIL VALVE REPAIR KIT K34124 IS TO CHANGE METHOD OF ASSEMBLING VALVE STEM & MANDREL FROM SETSCREW TO SHEAR-PROOF PIN, (NOTE: FOR VALVE STEMS & MANDRELS WHICH ARE ALREADY PINNED, ORDER INDIVIDUAL PARTS AS NEEDED).

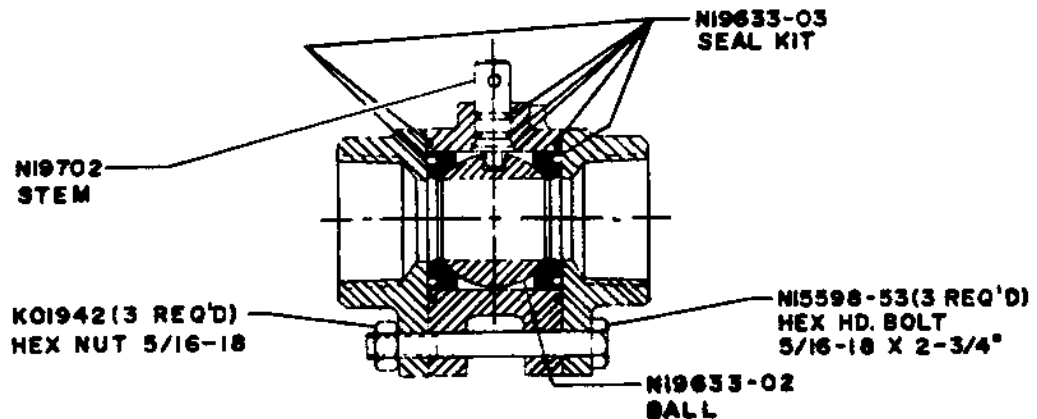

REPLACEMENT PARTS FOR OIL VALVE N19596

FIG 2