

PANZITTA SALES & SERVICE
72 George Avenue
Wilkes-Barre, PA 18705
570-822-6720 800-822-6720
www.panzittasales.com

MANITOWOC LIFTS

PARTS LIST

"SWING-RAIL®" SINGLE POST DRIVE OVER LIFT

A-1AA1A SERIES (SEMI-HYDRAULIC)

A-1AA3A SERIES (FULL HYDRAULIC)

SINGLE POST ALIGNMENT LIFT

A-1AN1A SERIES (SEMI-HYDRAULIC)

A-1AN3A SERIES (FULL HYDRAULIC)

Recommendations

AIR EXHAUST: Pipe air exhaust outside building when possible or install the MANITOWOC LIFTS silencer furnished with this lift. This eliminates noise and provides a much more satisfactory installation.

PIPING: Use only new pipe. See that threads are perfect. Use only metal-seated unions. Before using the pipe hammer it to loosen all scale, spelter and dirt and then wash the interior with kerosene. The pipe should pitch up gradually from the cylinder to control valve with no traps or low places. Use pipe sealing compound on the male threads of all screw connections, unless your local authorities require the use of some special material. Do not use on the female thread.

COMPRESSOR: The compressor should be of the two-stage type. Operating pressure range should be between 150-175 psi. Air pressure and tank storage size are important as they determine the lifting speed and capacity of the lift. All piping, fittings, and valves must have a rated burst pressure of not less than 875 psi (Five times the Maximum Operating Pressure). Do not use plastic piping, fittings, or valves.

INSTALLATION MUST BE MADE IN ACCORDANCE WITH LOCAL, STATE AND FEDERAL REGULATIONS AND IN STRICT CONFORMANCE WITH THESE INSTRUCTIONS.

USE ONLY MANITOWOC LIFTS AUTHORIZED REPLACEMENT PARTS.

A-1AA1A,A-1AA3A,A-1AN1A,A-1AN3A.max

When ordering replacement parts, always mention lift model number and serial number.

**SERIES A-1AA1A
SERIES A-1AA3A**

Code No. No. Req.	Symbol No.	Description	Code No. No. Req.	Symbol No.	Description	
A	1	T13961	P	8	K01909	Hex Hd. Bolt, 1/2"-13 x 1"
B	8	Q10412-15	Q	8	K02455	Lockwasher, 1/2"
C	1	K01914-64	R	1	K87578-02	Plastic Plug
D	4	R16123-02	S	8	K87578	Plastic Plug
E	4	R12709-02	T	2	K87578-01	Plastic Plug
F	4	Q10038-04	V	1	N20268-10	Automatic Lock Assy. (68° Rise) (See Page 12 or 13)
G	4	R12710-02	W	1	T13952-01	Plunger & Cylinder Assy. (Semi Hyd.) (68° Rise) (See Page 12)
H	4	K87033	W	1	T13946-01	Plunger & Cylinder Assy. (Full Hyd.) (68° Rise) (See Page 13)
J	4	R13252				
K	4	K02215				
L	4	K85825				
M	4	K78272				
N	4	N20366-01				

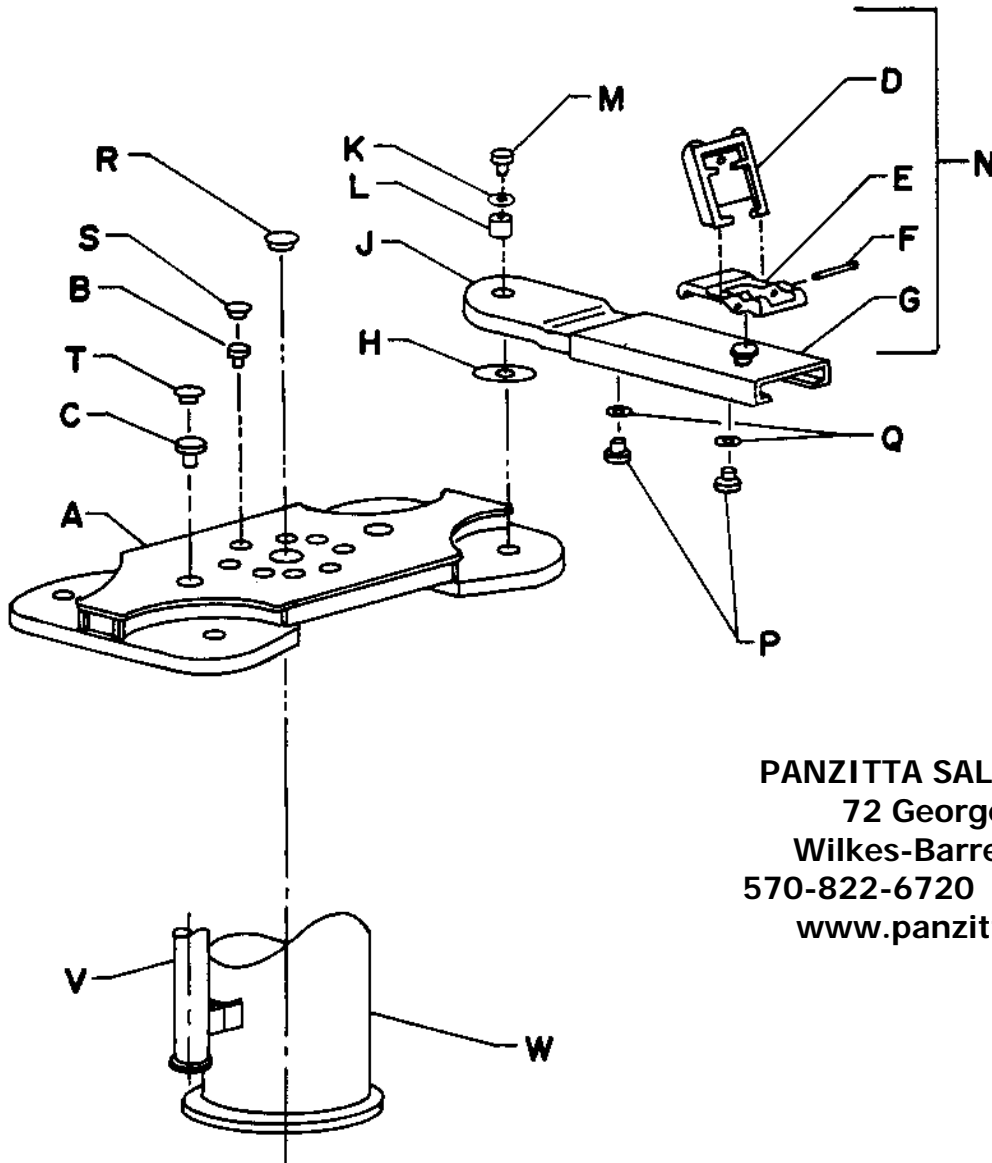

N21792

FIG. 6

CROSSHEAD

PANZITTA SALES & SERVICE
72 George Avenue
Wilkes-Barre, PA 18705
570-822-6720 800-822-6720
www.panzittasales.com

When ordering replacement parts, always mention lift model number and serial number.

Code No.	No. Req.	Symbol No.	Description
A	1	K81439	Muffler
B	1	N19687-01	Oil Gauge Assy. (1-1/2" Plug)
D	1	R18219-G1	Oil Tank with Oil Gauge Installed
E	1	K68832	Two-way Air Valve (See Page 17, Fig. 2)
H	1	R13325	Oil Valve (See Page 16, Fig. 1)
J	1	K86957	Float Assy.
K	1	K78439	Float
L	1	K80538	Rod Float
M	1	K04993	Hex Nut #8-32
N	2	K03782	Hex Hd. Bolt 5/16"-18 x 1-3/4"
P	1	T07915	Wheel Stop
R	2	K79695	Expansion Shield
S	1	K62563	Pull Rod

PANZITTA SALES & SERVICE
 72 George Avenue
 Wilkes-Barre, PA 18705
 570-822-6720 800-822-6720
www.panzittasales.com

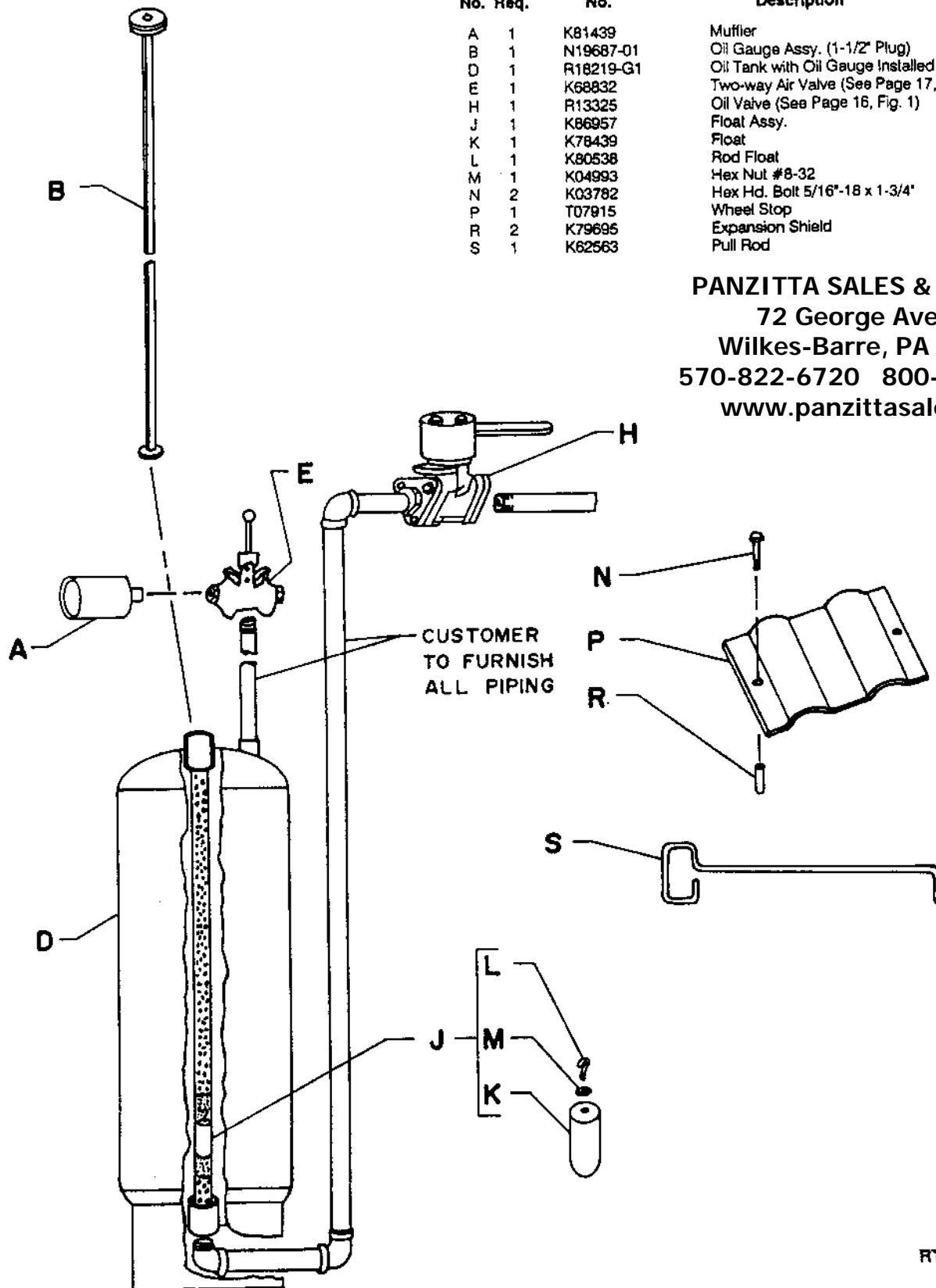

RT4635

OIL TANK, GAUGE, VALVES, ETC.

A-1AA1A, A-1AA3A, A-1AN1A, A-1AN3A SERIES

A-1AA1A,A-1AA3A,A-1AN1A,A-1AN3A.max

When ordering replacement parts, always mention lift model number and serial number.

Code No. No. Req.	Symbol No.	Description	Code No. No. Req.	Symbol No.	Description
			M	1	N21812-G1
A	1	Plunger & Cylinder Assy.	N	1	K01914-64
B	1	Cylinder Assembly	P	1	R13470-01
C	1	Plunger Assembly (See note)	R	1	R16245-02
D	1	Upper Bearing	S	2	K01901
E	1	Felt Wiper	T	1	N20268-10
F	12	Hex Hd. Bolt 3/4"-10 x 2-1/4"	U	1	R13365
G	1	Wiper Retainer	V	1	Q10068-32
H	6	Hex Hd. Bolt 7/16"-14 x 1-1/2"	W	1	N18842
J	1	Wiper	X	4	K47659
K	1	Seal	Y	1	N18490-02
L	1	O-Ring	Z	1	K02284
		Seal Kit (Includes D, H, J & K)			
					Air Vent
					Hex Hd. Bolt 1"-8 x 3"
					Telescoping Post & Latch Assy.
					Stationary Tube Assembly
					Hex Hd. Bolt 3/8"-16 x 3/4"
					Automatic Lock Assy. (Includes N, P, R & S)
					Low Oil Control
					O-Ring
					Cover
					Hex Hd. Bolt 3/8"-16 x 7/8"
					Oil Gauge
					Pipe Plug 1-1/4"

PANZITTA SALES & SERVICE
 72 George Avenue
 Wilkes-Barre, PA 18705
 570-822-6720 800-822-6720
 www.panzittasales.com

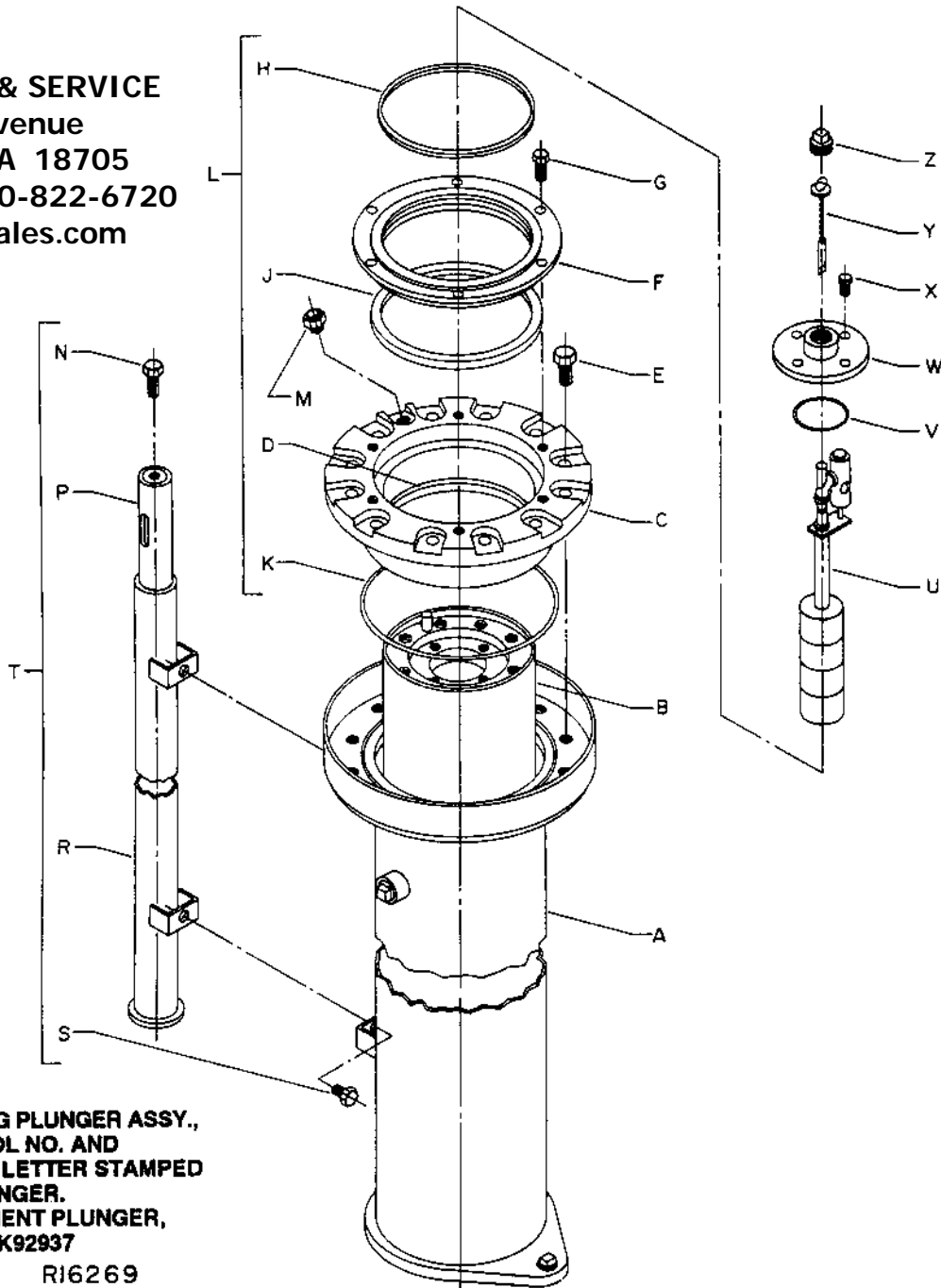

NOTE:
 WHEN ORDERING PLUNGER ASSY.,
 SPECIFY SYMBOL NO. AND
 BEARING CODE LETTER STAMPED
 ON TOP OF PLUNGER.
 FOR REPLACEMENT PLUNGER,
 ORDER KIT NO. K92937

R16269

PLUNGER AND CYLINDER ASSEMBLY (SEMI HYDRAULIC)

When ordering replacement parts, always mention lift model number and serial number.

Code No.	Symbol No.	Description
	1	T13946-01 Plunger & Cylinder Assembly
A	1	T13937-G1 Cylinder Assembly
B	1	T13935-G1 Plunger Assembly (See note)
C	1	T13943-02 Upper Bearing
D	1	Felt Wiper
E	12	Q10412-01 Hex Hd. Bolt 3/4"-10 x 2-1/4"
F	1	R18229-02 Wiper Retainer
G	6	K01907 Hex Hd. Bolt 7/16"-14 x 1-1/2"
H	1	Wiper
J	1	Seal
K	1	O-Ring
L	1	K34301 Seal Kit (Includes D, H, J & K)
M	1	N21812-G1 Air Vent
N	1	K01914-64 Hex Hd. Bolt 1"-8 x 3"
P	1	R13470-01 Telescoping Post & Latch Assy.
R	1	R16245-02 Stationary Tube Assembly
S	2	K01901 Hex Hd. Bolt 3/8"-16 x 3/4"
T	1	N20268-10 Automatic Lock Assembly (Includes N, P, R & S)

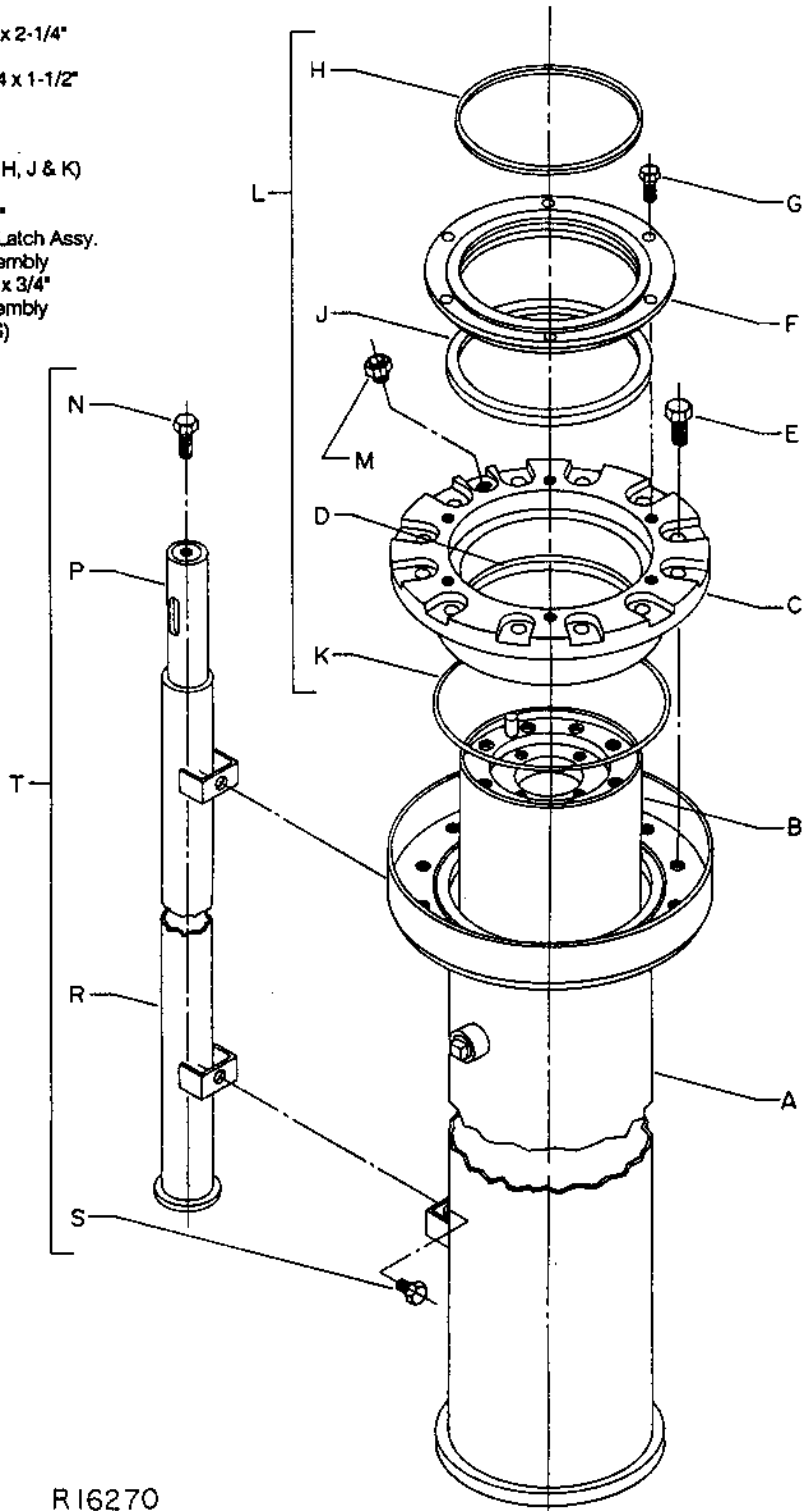

R16270

PANZITTA SALES & SERVICE
 72 George Avenue
 Wilkes-Barre, PA 18705
 570-822-6720 800-822-6720
 www.panzittasales.com

NOTE:
 WHEN ORDERING PLUNGER ASSY.,
 SPECIFY SYMBOL NO. AND
 BEARING CODE LETTER STAMPED
 ON TOP OF PLUNGER.
 FOR REPLACEMENT PLUNGER,
 ORDER KIT NO. K92935

PLUNGER AND CYLINDER ASSEMBLY (FULL HYDRAULIC)

A-1AA1A, A-1AA3A, A-1AN1A, A-1AN3A SERIES

A-1AA1A,A-1AA3A,A-1AN1A,A-1AN3A.max

When ordering replacement parts, always mention lift model number and serial number.

Code No. No. Req.	Symbol No.	Description	Code No. No. Req.	Symbol No.	Description		
A	1	N19192-01	Cover	G	1	K07801	Elbow 1/2" x 90°
B	1	T09397	Control Box	H	4	K01941	Hex Nut 1/4"-20
C	1	N19107	Air Control Handle Extension	J	2	K67996-02	U-Bolt 1/4"-20
E	2	K07798	Union 1/2"	K	1	K85963-03	Air Valve (See Page 17, Fig. 1)
F	1	K44745	Nipple 1/2" x 1-1/2"	L	1	K81439	Muffler
				M	1	N16771	1/2" Close Nipple

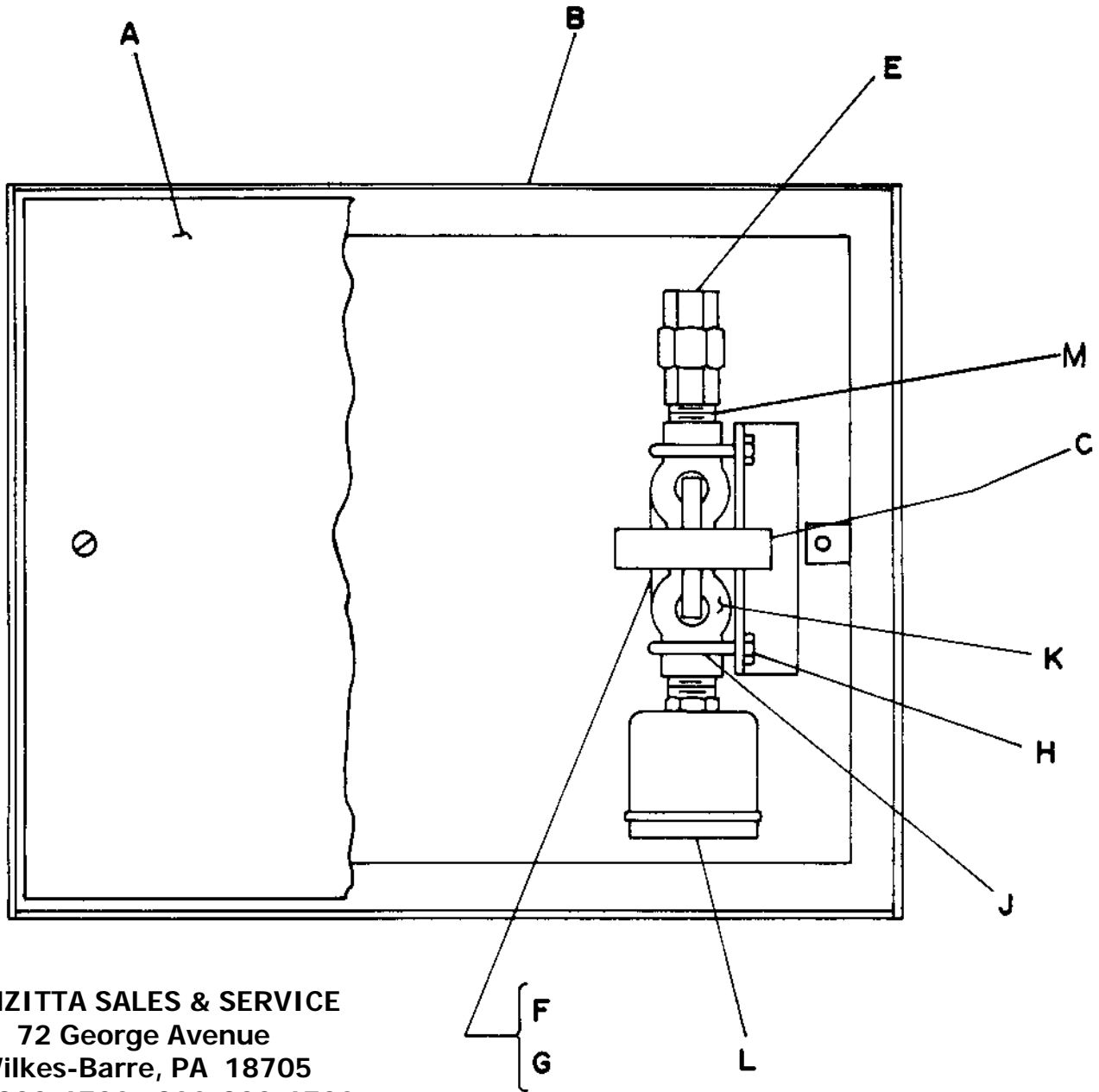

PANZITTA SALES & SERVICE
 72 George Avenue
 Wilkes-Barre, PA 18705
 570-822-6720 800-822-6720
 www.panzittasales.com

R13442

CONTROL BOX ASSEMBLY T09402 SEMI HYDRAULIC (OPTIONAL)

A-1AA1A, A-1AA3A, A-1AN1A, A-1AN3A SERIES

A-1AA1A,A-1AA3A,A-1AN1A,A-1AN3A.max

When ordering replacement parts, always mention lift model number and serial number.

Code No. No. Req.	Symbol No.	Description	Code No. No. Req.	Symbol No.	Description		
A	1	R13353	Cover	L	1	K81439	Muffler
B	1	T09397	Control Box	M	1	N19668	Bracket
C	1	N19184	Air Control Handle Extension	N	2	K67996-06	U-Bolt 1/4"-20
E	2	K07798	Union 1/2"	P	1	N19602	Oil Control Handle Extension
F	1	K44745	Nipple 1/2" x 1-1/2"	Q	2	R11494-24	Nipple 1/4" x 2-1/2"
G	1	K07801	Elbow 1/2" x 90°	R	1	R14467	Oil Valve (See Page 18, Fig. 2)
H	8	K01941	Hex Nut 1/4"-20	S	1	R13351	Oil Valve & Nipple Assy. (Includes Q & R)
J	2	K67996-02	U-Bolt 1/4"-20	T	1	N16771	1/2" Close Nipple
K	1	K85963-03	Air Valve (See Page 17, Fig. 1)				

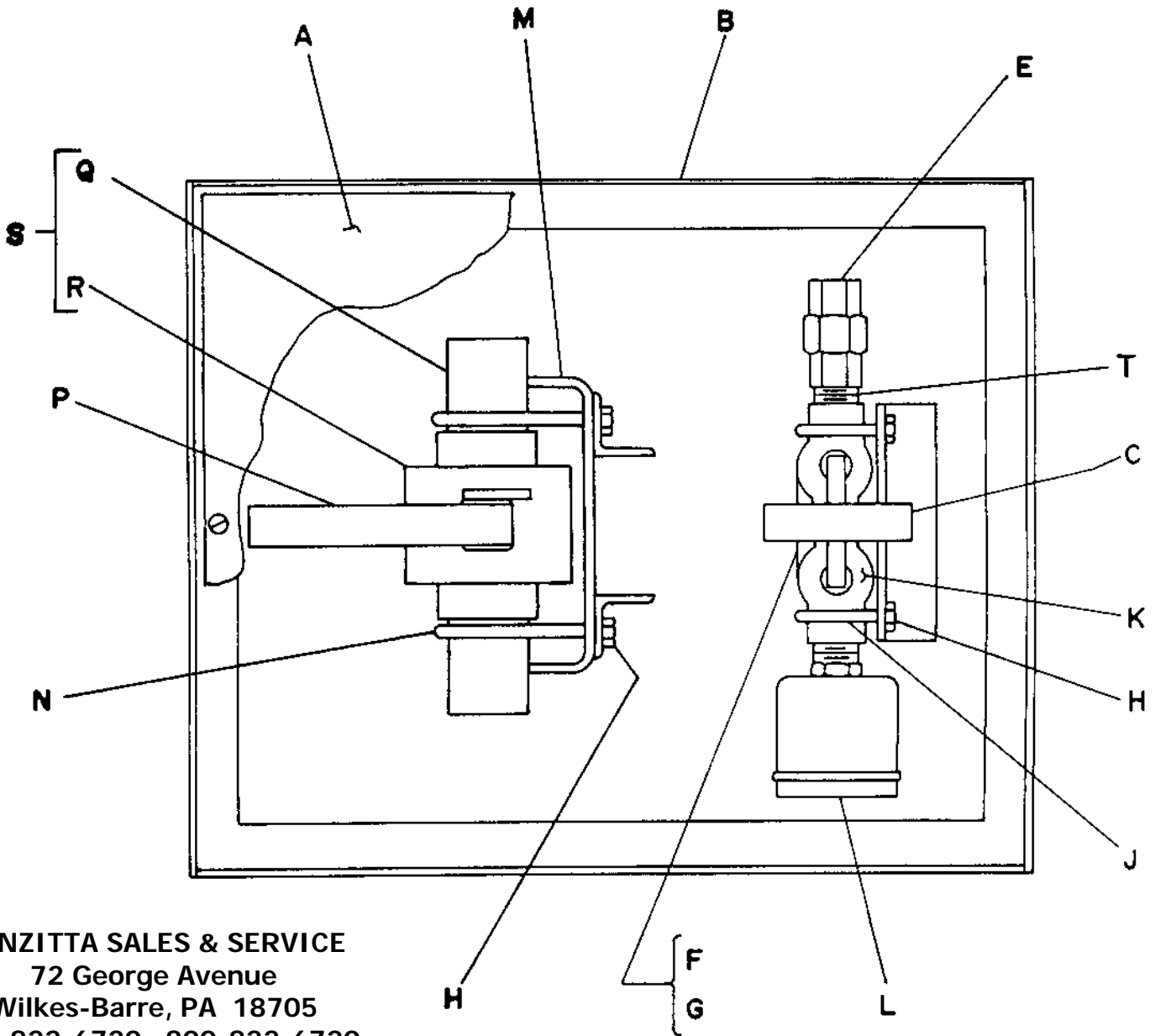

PANZITTA SALES & SERVICE
 72 George Avenue
 Wilkes-Barre, PA 18705
 570-822-6720 800-822-6720
 www.panzittasales.com

R13440

CONTROL BOX ASSEMBLY TO9395 FULL HYDRAULIC (OPTIONAL)

A-1AA1A, A-1AA3A, A-1AN1A, A-1AN3A SERIES

A-1AA1A,A-1AA3A,A-1AN1A,A-1AN3A.max

When ordering replacement parts, always mention lift model number and serial number.

PANZITTA SALES & SERVICE
 72 George Avenue
 Wilkes-Barre, PA 18705
 570-822-6720 800-822-6720
 www.panzittasales.com

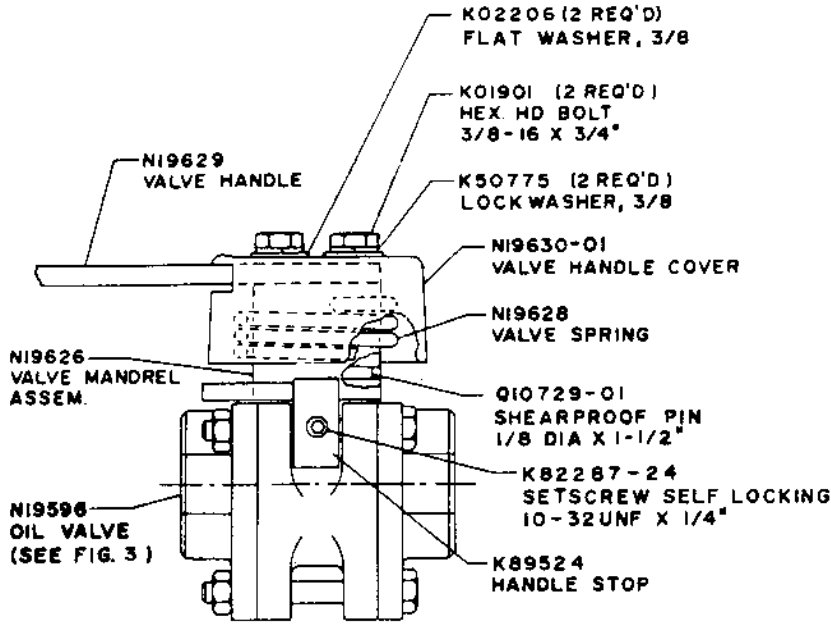

WALL CONTROL
 COMPLETE OIL VALVE ASSEMBLY R13325

FIG. 1

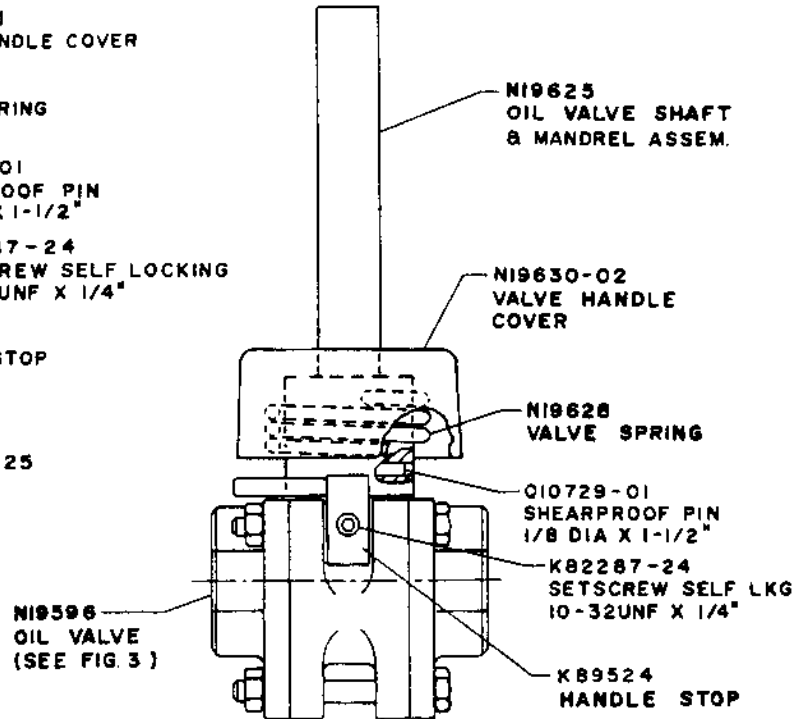

FLOOR CONTROL
 COMPLETE OIL VALVE ASSEMBLY R14467

FIG. 2

NOTE: THE REPAIR KITS FOR OIL VALVES LISTED BELOW ARE USED TO CHANGE METHOD OF ASSEMBLING VALVE STEM & MANDREL FROM SETSCREW TO SHEARPROOF PIN. (NOTE: FOR VALVE STEMS AND MANDRELS WHICH ARE ALREADY PINNED, ORDER INDIVIDUAL PARTS AS NEEDED).
 WALL CONTROL REPAIR KIT K34123
 FLOOR CONTROL REPAIR KIT K34124

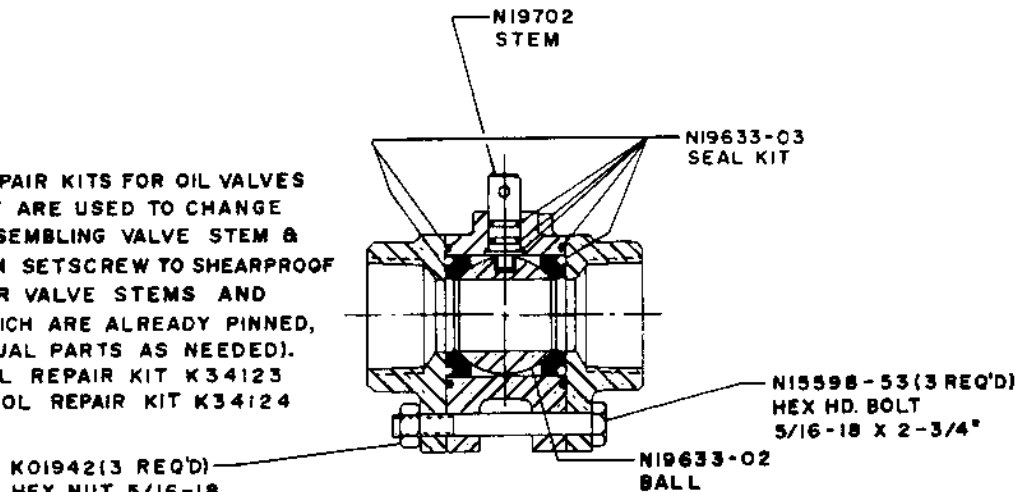

REPLACEMENT PARTS FOR OIL VALVE NI9596

FIG. 3

OIL VALVE

A-1AA1A, A-1AA3A, A-1AN1A, A-1AN3A SERIES

A-1AA1A,A-1AA3A,A-1AN1A,A-1AN3A.max

When ordering replacement parts, always mention lift model number and serial number.

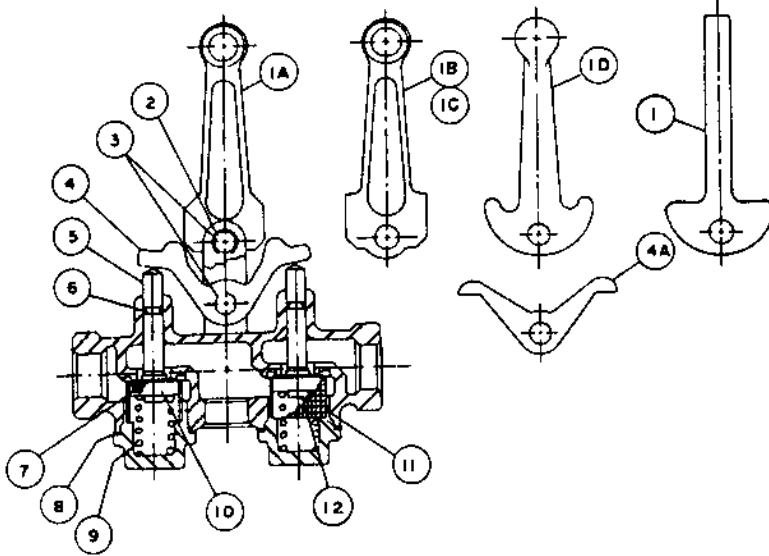

SYM	SYMBOL NO.		QTY	DESCRIPTION
	CONS. BRASS	KINGSTON		
1		N19106	1	LEVER, FLOOR CONTROL
1A	N19494-28		1	LEVER, LOCKING
1B	N19494-27		1	LEVER, NON-LOCKING
1C		KB2714-20	1	LEVER, LOCKING
1D		KB2714-35	1	LEVER, NON-LOCKING
2	N19494-32	N19494-32	4	RETAINING RING
3	N19494-30	N19494-30	2	CLEVIS PIN
4	N19494-29		1	ROCKER ARM
4A		KB2714-23	1	ROCKER ARM
5	N19494-26	KB2714-28	2	STEM
6	N19494-21	KB2714-27	2	O RING
7	N19494-22	KB2714-29	2	SEAT WASHER
8	N19494-23		2	FIBER WASHER
9	N19494-20	KB2714-32	2	SPRING
10	N19494-25	KB2714-30	2	SEAT HOLDER
11	N19494-31		2	SCREEN
12		KB2714-31	2	STEM NUT

PANZITTA SALES & SERVICE
 72 George Avenue
 Wilkes-Barre, PA 18705
 570-822-6720 800-822-6720
 www.panzittasales.com

FIG. 1

TO ORDER A COMPLETE VALVE ASSEMBLY, THE PART NUMBERS ARE:
 LOCKING TYPE (FULL HYDRAULIC WALL CONTROL) - K68832
 DEADMAN TYPE (SEMI-HYDRAULIC WALL CONTROL) - K85963 & K85963-02
 DEADMAN TYPE (ALL FLOOR CONTROL) - K85963-03

FOR AIR VALVE REPLACEMENT PARTS, FIRST DETERMINE MFR. OF VALVE:
 IF MFR. IS KINGSTON, USE PARTS LIST ABOVE (FIG. 1)
 IF MFR. IS CONSOLIDATED BRASS AND VALVE HAS A ONE-PIECE CAST HANDLE,
 USE PARTS LIST ABOVE (FIG. 1)
 IF MFR. IS CONSOLIDATED BRASS AND VALVE HAS A TWO-PIECE HANDLE WITH
 A PLASTIC KNOB, USE PARTS LIST BELOW (FIG. 2)

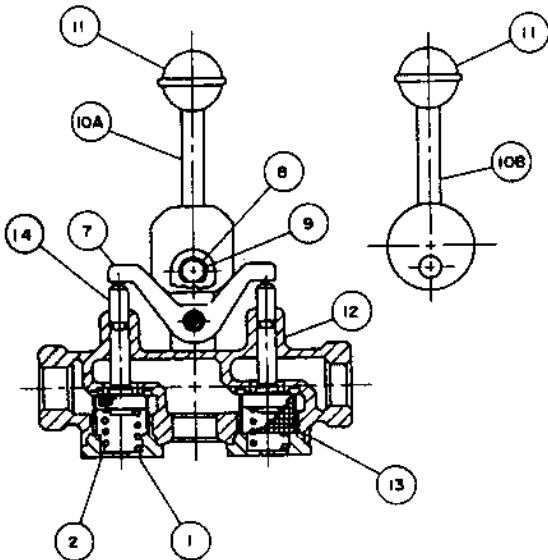

SYM	SYMBOL NO.		QTY	DESCRIPTION
	CONS. BRASS			
1	N20389-01		2	CAP
2	N20389-02		2	SPRING
7	N20389-07		1	ROCKER
8	N20389-08		2	CLEVIS PIN
9	N20389-09		4	RETAINING RING
10A	N20389-10		1	LEVER, LOCKING
10B	N20389-11		1	LEVER, NON-LOCKING
11	N20389-12		1	KNOB
12	N20389-13		1	BODY
13	N20389-14		2	SCREEN
14	N20389-15		2	STEM ASSEMBLY

FIG. 2

R14580

AIR VALVE

A-1AA1A, A-1AA3A, A-1AN1A, A-1AN3A SERIES

Page 17

A-1AA1A,A-1AA3A,A-1AN1A,A-1AN3A.max