

**THESE LIFTS ARE DESIGNED
FOR MANY PASSENGER CARS,
LIGHT TRUCKS AND VANS**

SEE BACK COVER FOR LIFTING CAPACITY
AND APPROX. OIL REQUIRED TO FILL SYSTEM



This Automotive Lift complies with all applicable requirements of American National Standard ANSI B153.1 - 1981 as issued by American National Standards Institute, Inc.

CHECK SHIPMENT FOR:

DAMAGE: Contact delivering carrier for claim.

SHORTAGE: Contact delivering carrier for claim if missing items on the Bill of Lading.

For missing parts within carton, contact seller.



**MP-28A SPEC 3860
MP-28E SPEC 3861
SERIES V**

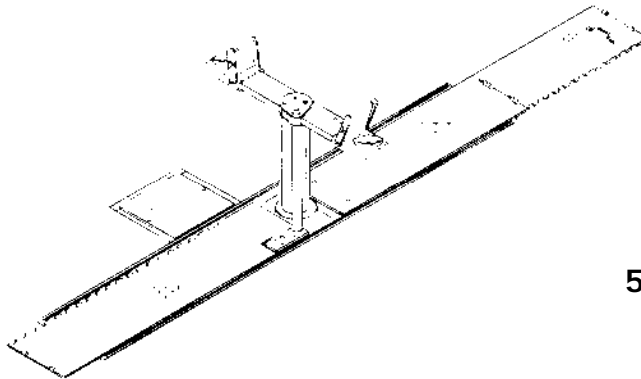
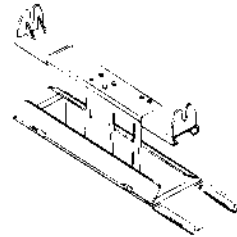

PANZITTA SALES & SERVICE
72 George Avenue
Wilkes-Barre, PA 18705
570-822-6720 800-822-6720
www.panzittasales.com

**MP-810A SPEC 3862
MP-810E SPEC 3863
SERIES V**

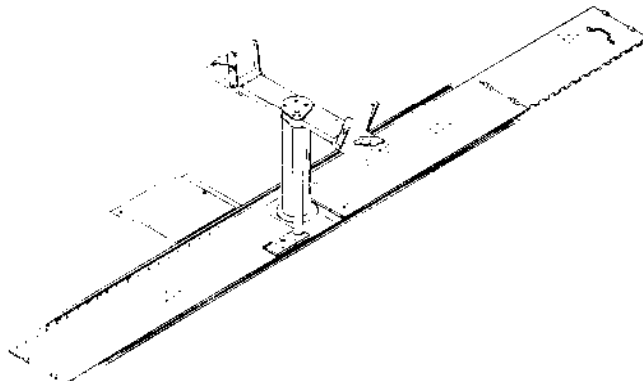
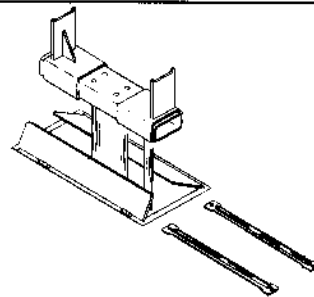

LOW OIL CONTROL - GAUGE STICK

The Low Oil Control Assembly consisting of valve float and rod are shipped as an assembly in the tank. Make sure the valve ass'y is properly located in the seat in the tank bottom. If not, rod will protrude above top of tank.

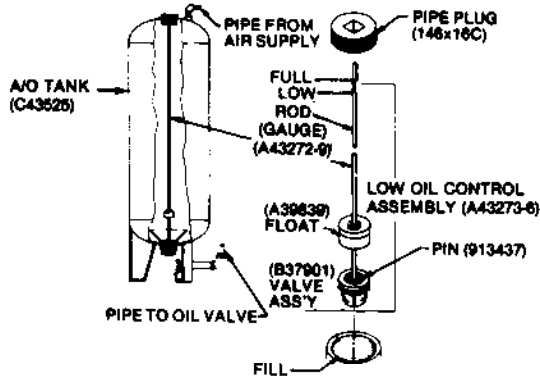

PUMP UNIT

(Also See Page 17)

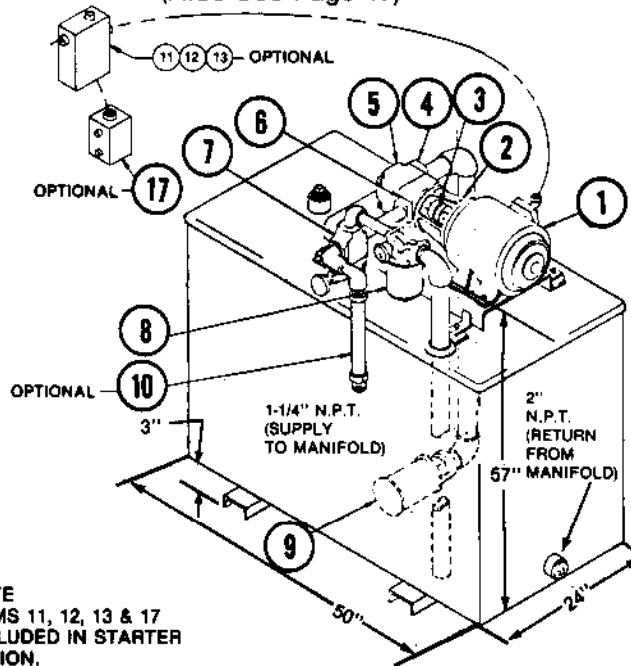

NOTE
ITEMS 11, 12, 13 & 17
INCLUDED IN STARTER
OPTION.

ITEM	PART NO.	DESCRIPTION
17	C43784-17	REMOTE PUSH BUTTON & ENCLOSURE
13	C43784-13	CONTROL TRANSFORMER 120V.
	C43784-12C	HEATER 5 HP 208V./240V.
	C43784-12C	HEATER 5 HP 480V.
	C43784-12A	HEATER 7-1/2 HP 208V./240V.
12	C43784-12	HEATER 7-1/2 HP 480V.
11	C43784-11	STARTER 3 PH.
10	C43784-10	HOSE
9	C43784-9	INLET STRAINER
8	C43784-8	LINE FILTER
7	C43784-7	RELIEF VALVE
6	C43784-6	OUTLET FLANGE
5	C43784-5	INLET FLANGE
4	C43784-4	PUMP
	C43784-3A	7.5 HP MOTOR COUPLING
	C43784-3	5 HP MOTOR COUPLING
	C43784-2	MOTOR BRACKET
	C43784-1C	7.5 HP MOTOR (EXPORT)
	C43784-1A	7.5 HP MOTOR
1	C43784-1	5 HP MOTOR

SUPERSTRUCTURE ATTACHMENT - FRONT

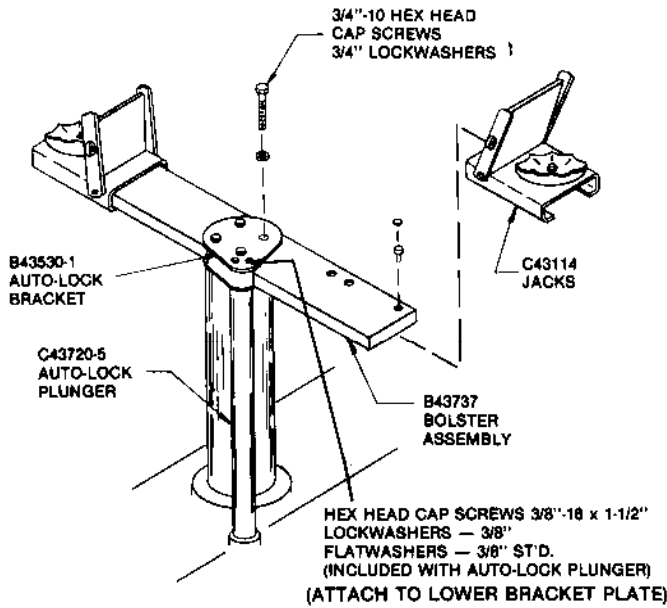

NOT SHOWN: CYL. POSITIONING HANDLE
(B42887)

SUPERSTRUCTURE ATTACHMENT - REAR MP-28

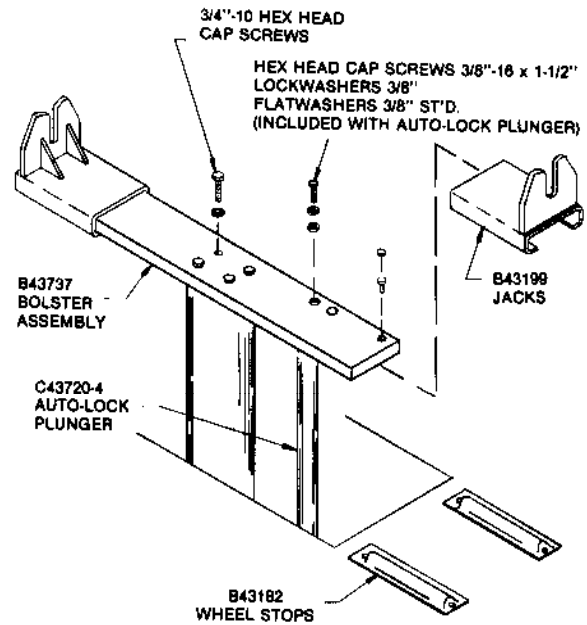

NOT SHOWN: JACK HOOK B37227-4

(TIGHTNESS OF ALL CAP SCREWS MUST BE MAINTAINED FOR PROPER SAFE OPERATION OF LIFT)
CHECK FOR PROPER OPERATION AND TIGHTEN ALL CAP SCREWS TO 100 FT LB TORQUE

SUPERSTRUCTURE ATTACHMENT - REAR MP-810

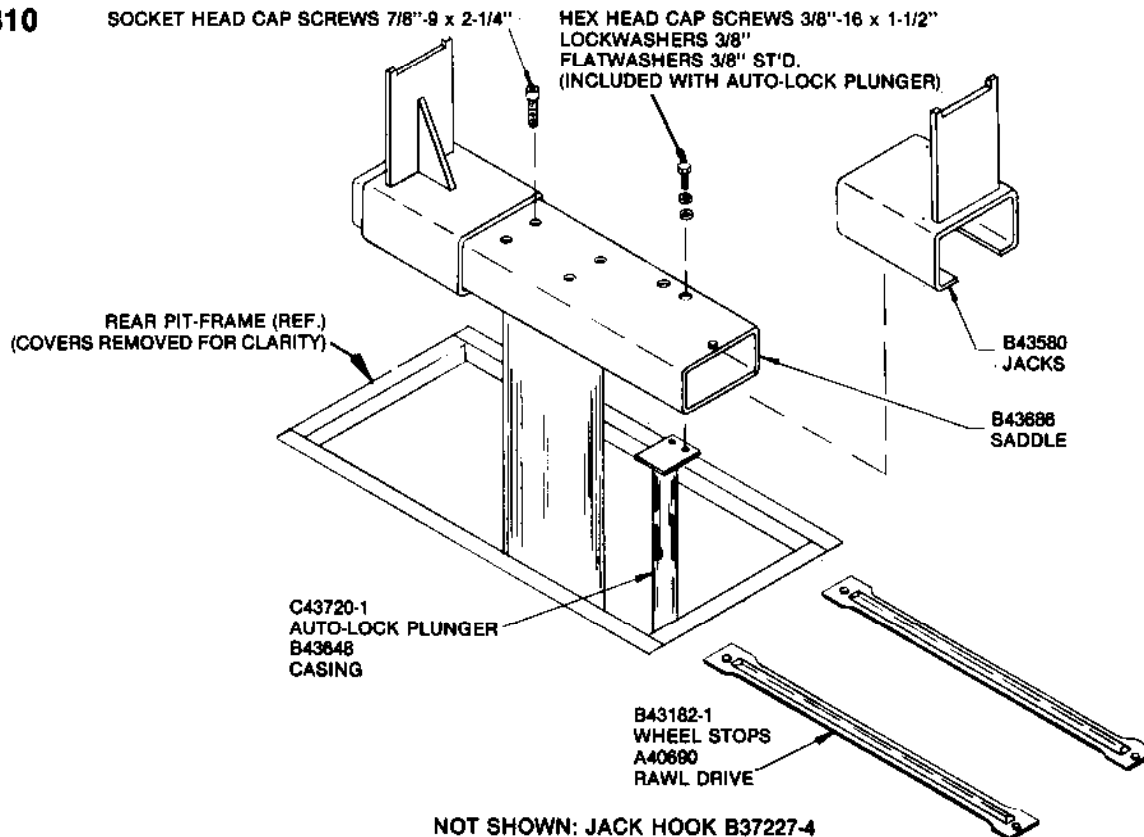

NOT SHOWN: JACK HOOK B37227-4

(TIGHTNESS OF ALL CAP SCREWS MUST BE MAINTAINED FOR PROPER SAFE OPERATION OF LIFT)
CHECK FOR PROPER OPERATION AND TIGHTEN ALL CAP SCREWS TO 100 FT LB TORQUE

PANZITTA SALES & SERVICE
72 George Avenue
Wilkes-Barre, PA 18705
570-822-6720 800-822-6720
www.panzittasales.com

FRONT PIT COVERS INSTALLATION

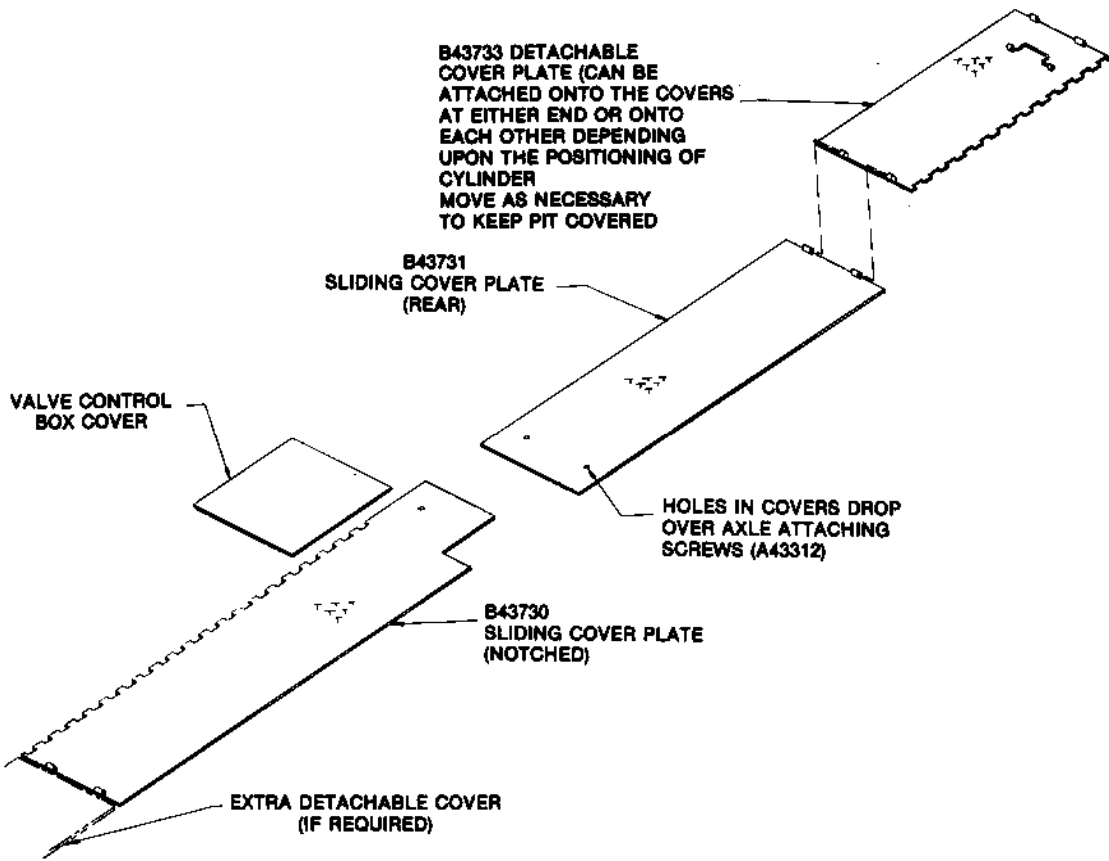

AIR VALVE PARTS

Should the air control valve leak, it may be due to a scored valve disc or seat. This is caused by grit, sand or pipe cuttings lodged on valve seat and forced into composition disc when the valve is closed. Valve can be repaired without removing it from the pipe line. Unscrew bottoms of lever

valves, clean screen seat and disc. If seat is scored, grind out score.

Leakage may occur around valve stem. To correct, lubricate stem and tighten down on packing nut.

571x4L COMPLETE VALVE ASSEMBLY

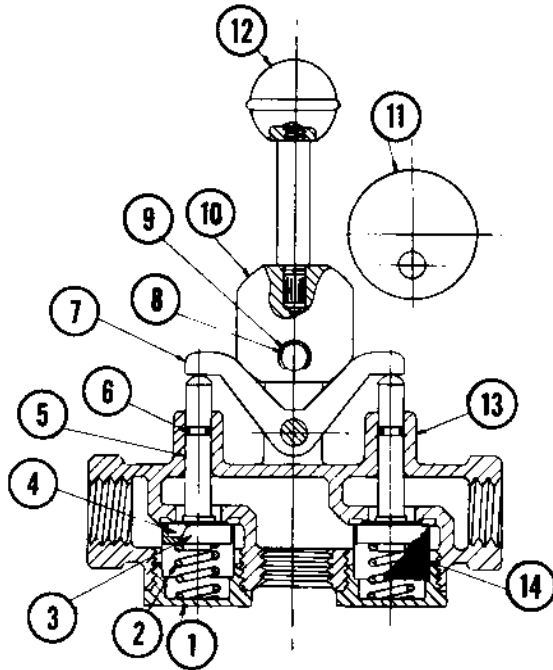

Ref. No.	Quan.	Part No.	Description
1	2	B43414-1	Cap
2	2	B43414-2	Spring
*3	2	B43414-3	Seat Holder
*4	2	B43414-4	Seat Disc
*5	2	B43414-5	Stem
*6	2	B43414-6	"O" Ring
7	1	B43414-7	Rocker
8	2	B43414-8	Clevis Pin
9	4	B43414-9	Retaining Ring
10	1	B43414-10	Cam Ass'y (Lock)
11	1	B43414-11	Cam Ass'y (Non-Lock)
12	1	B43414-12	Knob
13	1	B43414-13	Body
14	2	B43414-14	Screen
15	1	B43414-15	Tag

*These items included in:
B43414-16 Replacement Stem Ass'y

OIL VALVE PARTS

601x8 - 1" BALL VALVE - UNION END - COMPLETE VALVE ASSEMBLY

603x8 - 1" BALL VALVE - SPRING RETURN - COMPLETE VALVE ASSEMBLY--(WALL CONTROL USAGE)

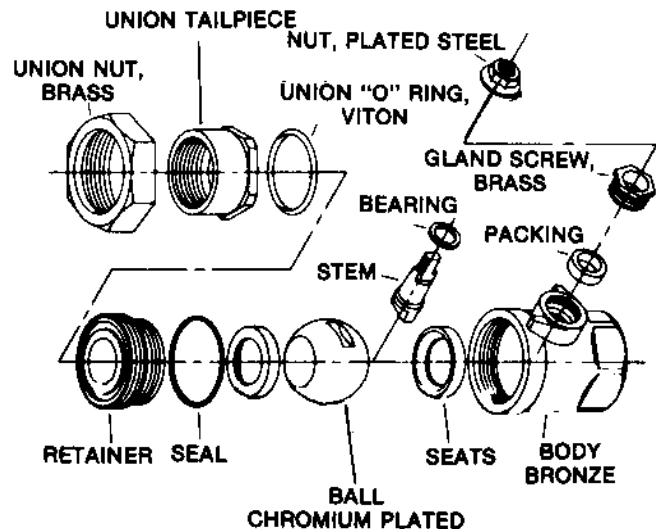
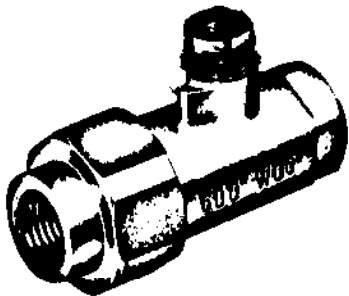

A43780 - SERVICE KIT
CONTAINS:
SEAT (2), PACKING & BEARING

CONTROL VALVE MANIFOLD — AIR/OIL OPERATED

WHEN IT IS DESIRED TO STOP LIFT CARE SHOULD BE TAKEN TO ASSURE THAT ALL VALVES ARE COMPLETELY CLOSED. DO NOT RELY ON THE VALVE SPRING.

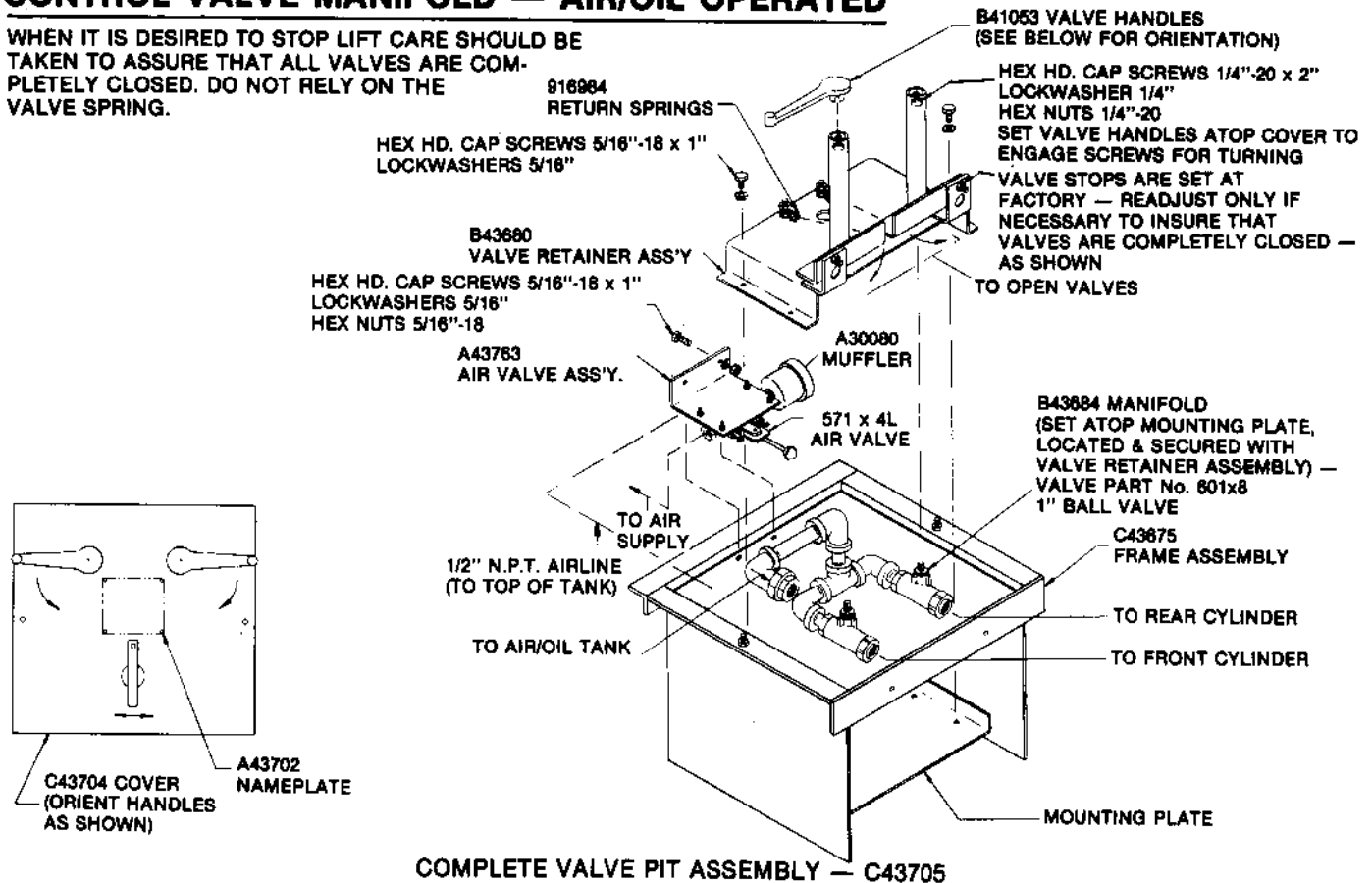

CONTROL VALVE MANIFOLD — PUMP OPERATED

WHEN IT IS DESIRED TO STOP LIFT CARE SHOULD BE TAKEN TO ASSURE THAT ALL VALVES ARE COMPLETELY CLOSED. DO NOT RELY ON THE VALVE SPRING.

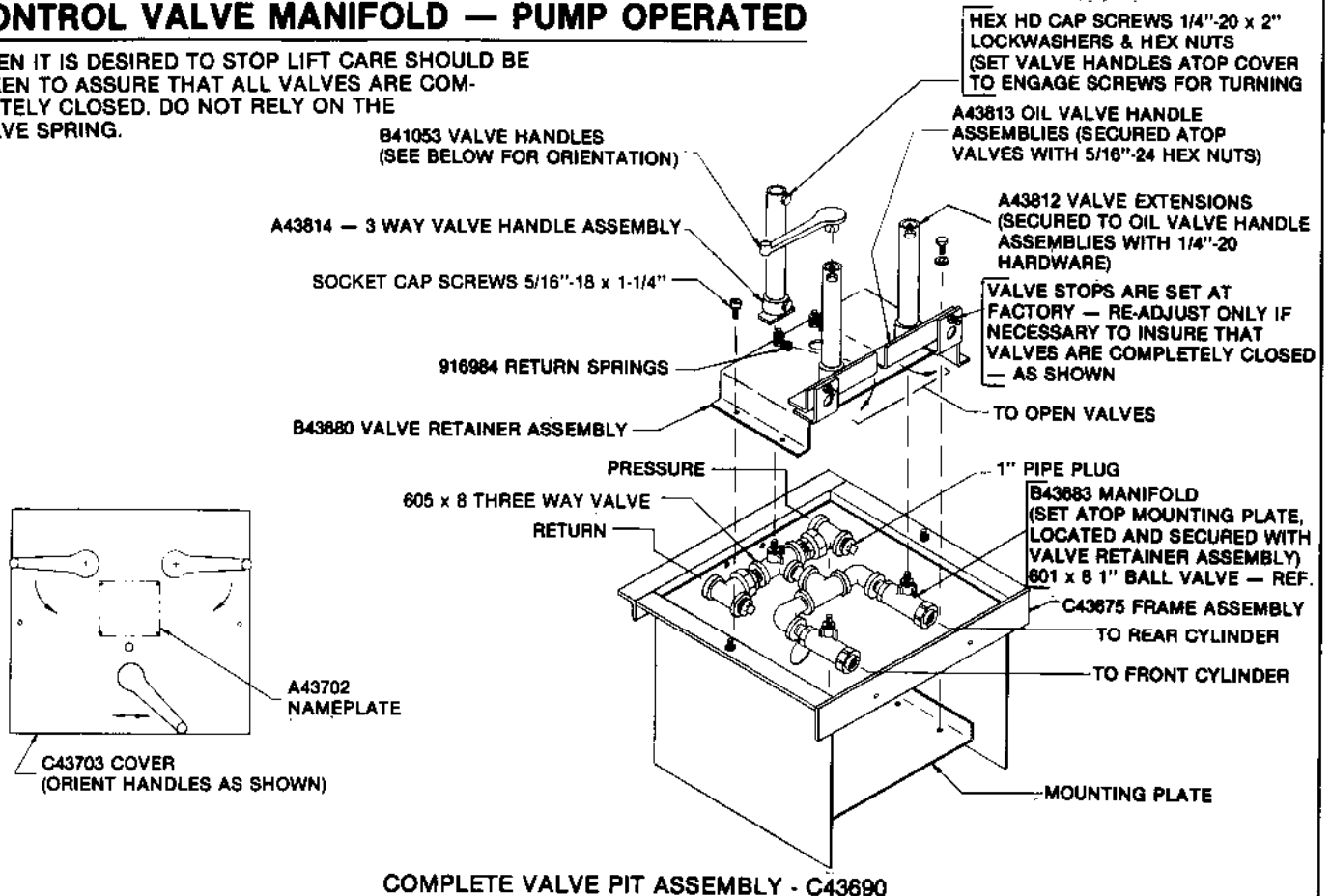

**FRONT CYLINDER ASSEMBLY MOVABLE POST
(C43745)**

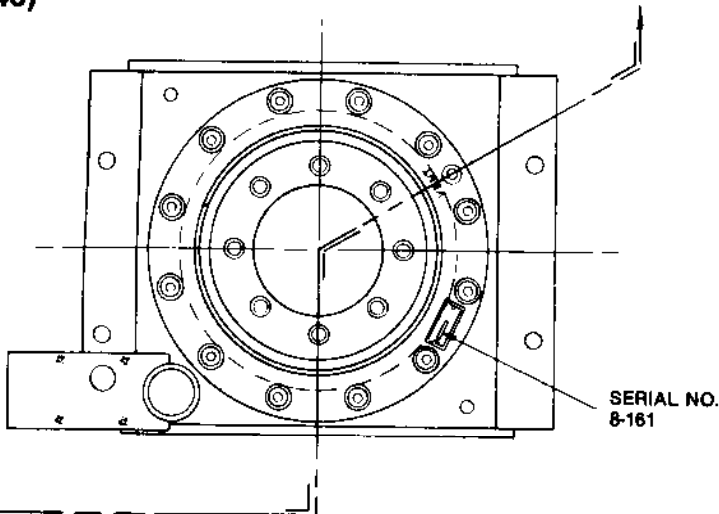

SERIAL NO.
8-161

Item	Part No.	Description
1	335X8	Wiper Packing
2	549X8	Wiper Spring
3	B37444	Wiper Seal Gasket
4	B37440	Wiper Seal Cover
5	B37447	Holder Ring
6	323X8	"U" Packing
7	B37446	Flange Gasket
8	B37457	Packing Spring
9	B37441	Upper Guide Bearing
10	B37442-18	Plunger Assembly
11	B43744	Casing Assembly

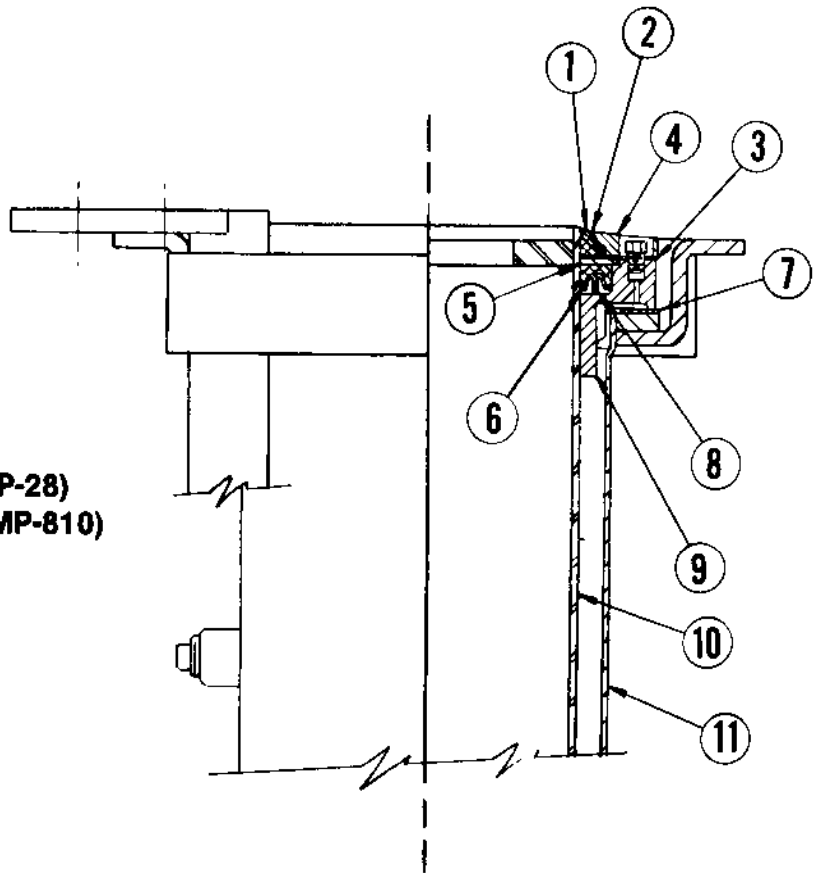

**REAR CYLINDER ASS'Y (C42908-2 MP-28)
(C35574-17 MP-810)**

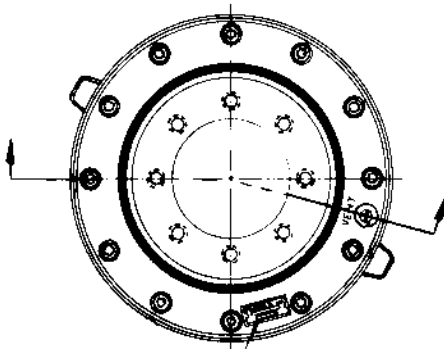

SERIAL NO. 8-150 (8" CYLINDER)
10-159 (10" CYLINDER)

Item	MP-28 Part No.	MP-810 Part No.	Description
1	335X8	335X10	Wiper Packing
2	549X8	549X10	Wiper Spring
3	B37444	B35092	Wiper Seal Gasket
4	B37440	B35064	Wiper Seal Cover
5	B37447	B35056	Holder Ring
6	323X8	323X10	"U" Packing
7	B37446	B35052	Flange Gasket
8	B37457	B37354	Packing Spring
9	B37441	B35055	Upper Guide Bearing
10	B37442-14	B35570-22	Plunger Assembly
11	B42577-4	B35573-6	Casing Assembly

Not Shown:
Plunger lower guide bearing — B41584 (8" Cylinder)
B41589 (10" Cylinder)

Note:
Items 1, 2, 3, 6, 7, & 8
supplied in Kit UW-81

PANZITTA SALES & SERVICE
72 George Avenue
Wilkes-Barre, PA 18705
570-822-6720 800-822-6720
www.panzittasales.com