



SERVICE PARTS

Model FS-10 Series

“Frame Kontakt” Lift

with Offset Arms

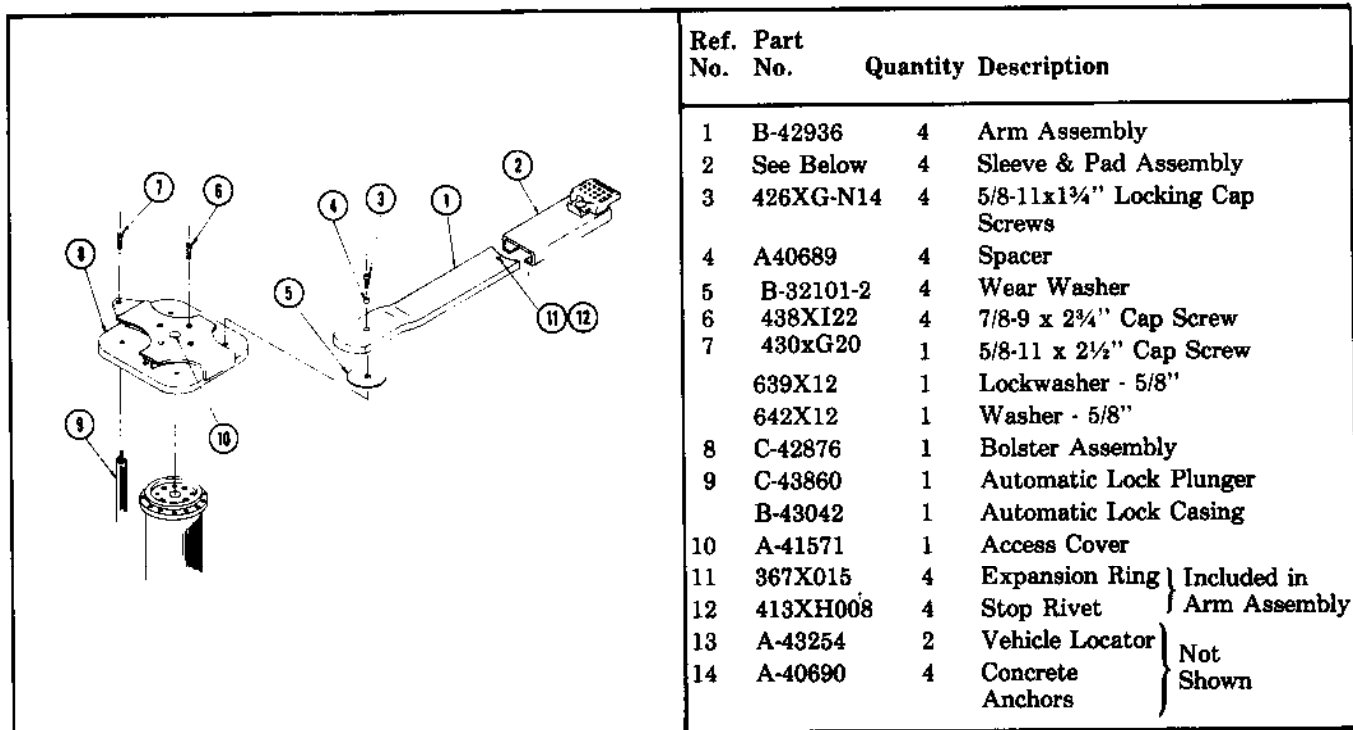

FIGURE 4-1. FS-10 SUPERSTRUCTURE ASSEMBLY

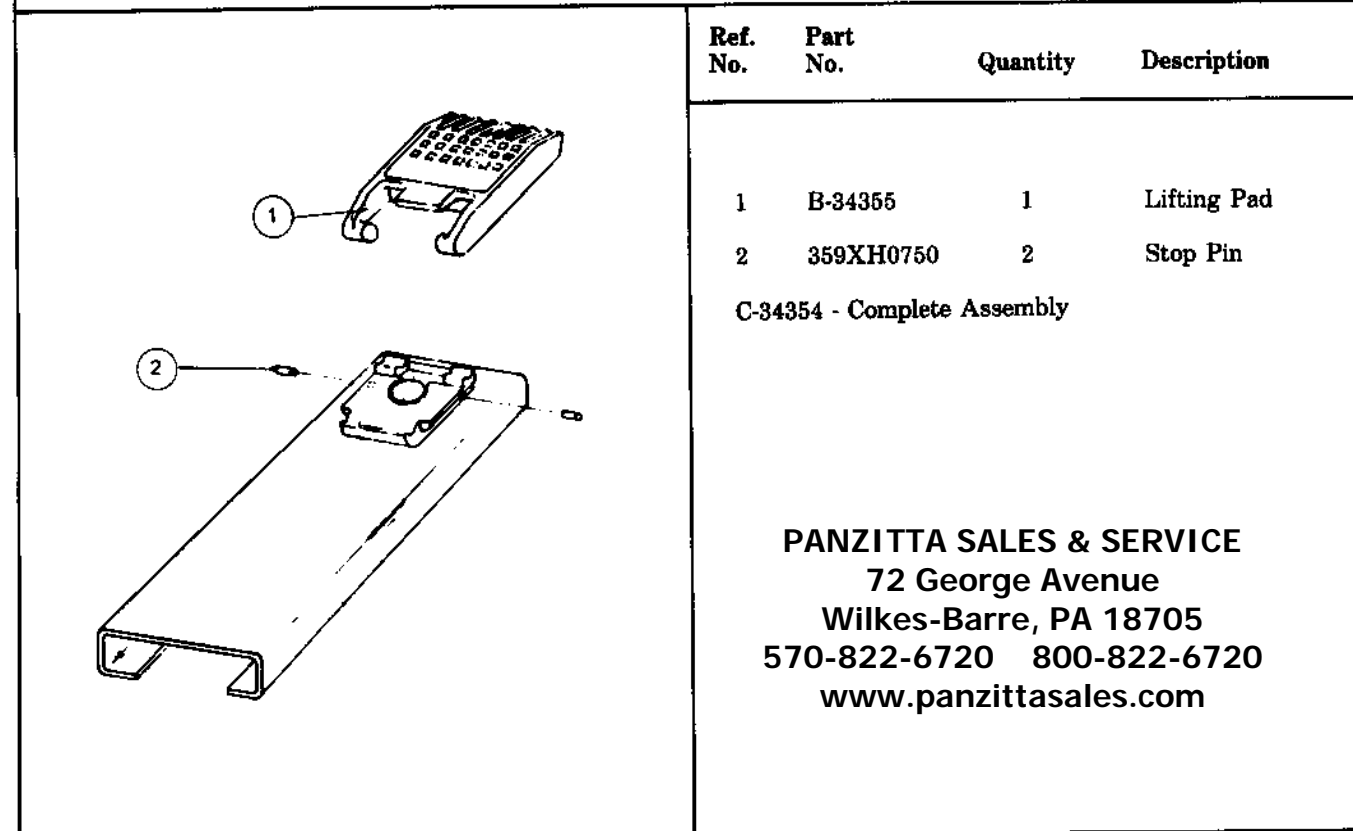
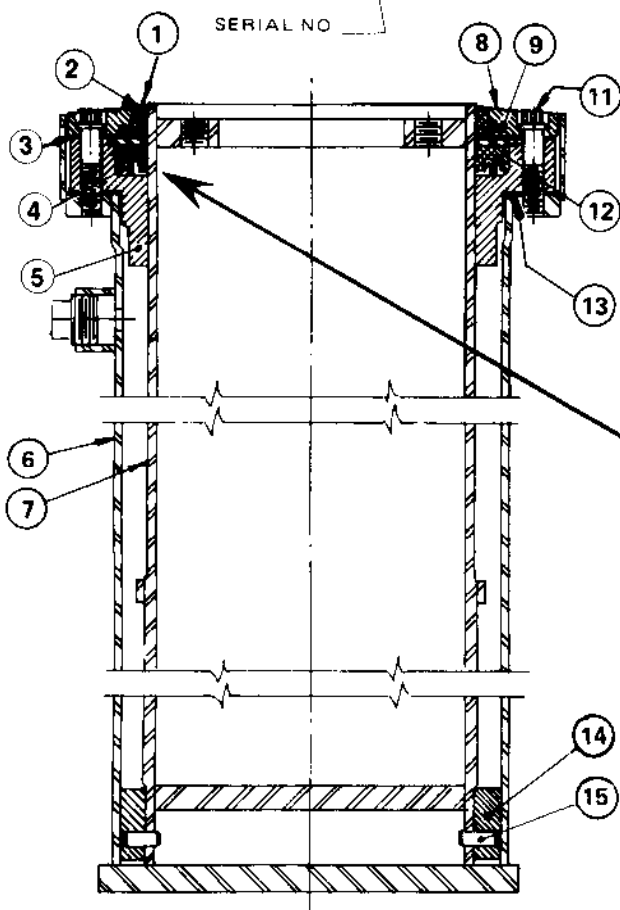
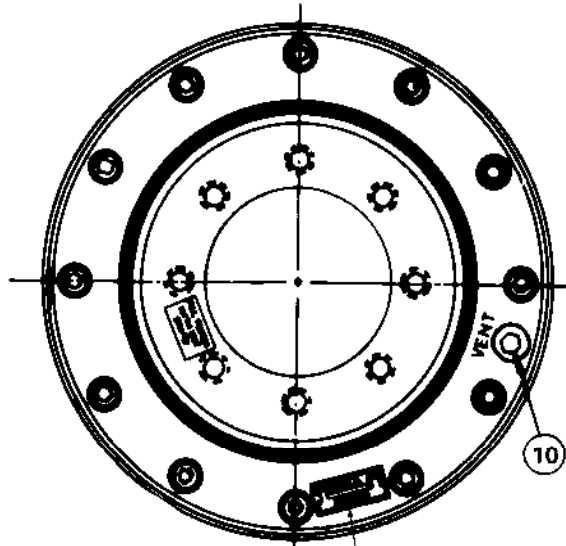

FIGURE 4-2. PAD AND SLEEVE ASSEMBLY (4 POSITION)



Ref. No.	Part No.	Quantity	Description
	C-35574-10	1	BS Cylinder Assembly Complete
1	335x10	1	Wiper Packing
2	549x10	1	Wiper Spring
3	B-35992	1	Wiper Seal Gasket
4	B-37354	1	Packing Spring
*5	B-35055	1	Upper Guide Bearing
6	B-35573-6	1	Casing Assembly
*7	B-35570-12	1	Plunger Assembly
8	B-35054	1	Wiper Seal Cover
9	B-35056	1	Holder Ring
10	118839	1	Bleeder Plug
11	438xG22	12	5/8-11x2 3/4 Cap Screw
12	323x10	1	"U" Packing
13	B-35052	1	Flange Gasket
*14	B-41569	1	Lower Guide Bearing
15	359xM1250	2	Spring Pin

\* NOTE: To receive the correct size upper and lower guide bearing the cylinder serial number must be given when ordering parts.

Items 1, 2, 3, 4, 12 and 13 are supplied in Kit UW-102.

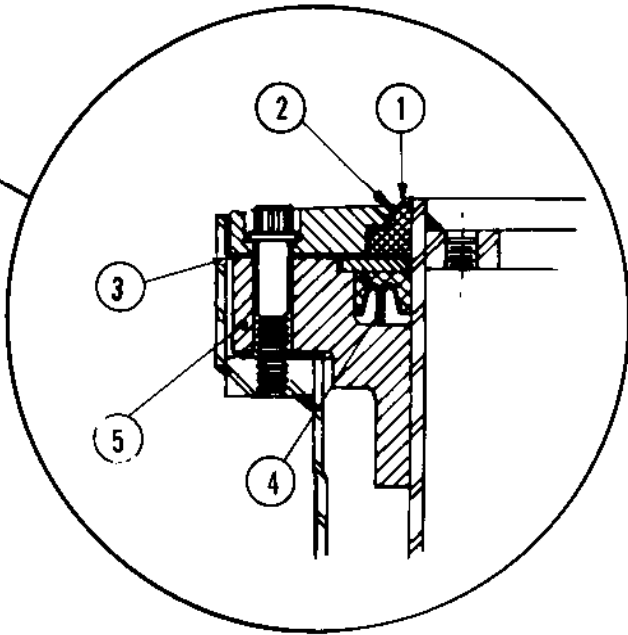

**FIGURE 4-3. BS CYLINDER ASSEMBLY**  
Full Hydraulic Type "WA" Cylinder (67 1/2" Stroke)

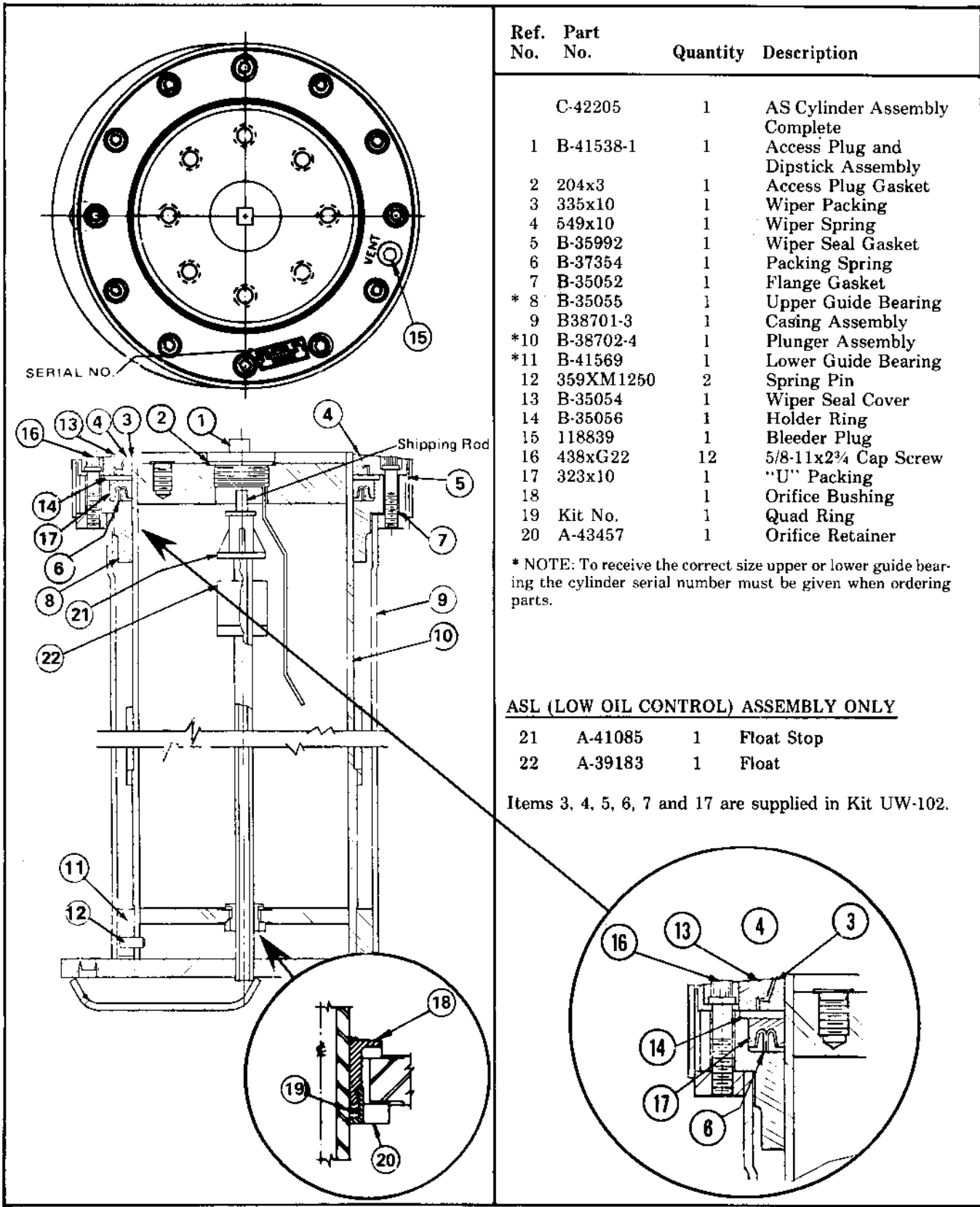

Ref. No.	Part No.	Quantity	Description
	C-42205	1	AS Cylinder Assembly Complete
1	B-41538-1	1	Access Plug and Dipstick Assembly
2	204x3	1	Access Plug Gasket
3	335x10	1	Wiper Packing
4	549x10	1	Wiper Spring
5	B-35992	1	Wiper Seal Gasket
6	B-37354	1	Packing Spring
7	B-35052	1	Flange Gasket
* 8	B-35055	1	Upper Guide Bearing
9	B38701-3	1	Casing Assembly
*10	B-38702-4	1	Plunger Assembly
*11	B-41569	1	Lower Guide Bearing
12	359XM1250	2	Spring Pin
13	B-35054	1	Wiper Seal Cover
14	B-35056	1	Holder Ring
15	118839	1	Bleeder Plug
16	438xG22	12	5/8-11x2 3/4 Cap Screw
17	323x10	1	"U" Packing
18		1	Orifice Bushing
19	Kit No.	1	Quad Ring
20	A-43457	1	Orifice Retainer

\* NOTE: To receive the correct size upper or lower guide bearing the cylinder serial number must be given when ordering parts.

**ASL (LOW OIL CONTROL) ASSEMBLY ONLY**

21	A-41085	1	Float Stop
22	A-39183	1	Float

Items 3, 4, 5, 6, 7 and 17 are supplied in Kit UW-102.

**FIGURE 4-4. AS CYLINDER ASSEMBLY**  
Semi-Hydraulic Type "WB" Cylinder (67 1/2" Stroke)

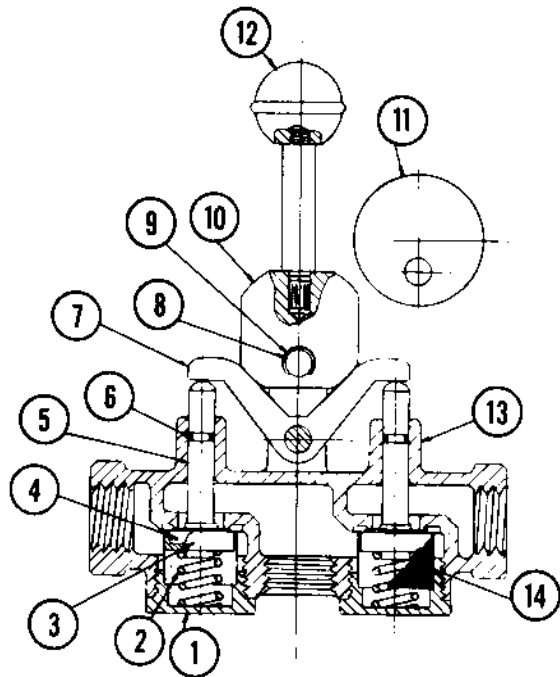

Ref. No.	Part No.	Quantity	Description
1	B-43414-1	2	Cap
2	B-43414-2	2	Spring
*3	B-43414-3	2	Seat Holder
*4	B-43414-4	2	Seat Disc
*5	B-43414-5	2	Stem
*6	B-43414-6	2	"O" Ring
7	B-43414-7	1	Rocker
8	B-43414-8	2	Clevis Pin
9	B-43414-9	4	Retaining Pin
10	B-43414-10	1	Cam Assembly (Lock)
11	B-43414-11	1	Cam Assembly (Non-Lock)
12	B-43414-12	1	Knob
13	B-43414-13	1	Body
14	B-43414-14	2	Screen
15	B-43414-15	1	Tag

\*These items included in B-43414-16 Replacement Stem Assembly.

Should the air control valve leak, it may be due to a scored valve disc or seat. This is caused by grit, sand or pipe cuttings lodged on valve seat and forced into composition disc when the valve is closed. Valve can be repaired without removing it from the pipe line. Unscrew bottoms of lever valves,

clean screen seat and disc. If seat is scored, grind out score.

Leakage may occur around valve stem. To correct, lubricate stem and tighten down on packing nut.

**FIGURE 4-5. AIR VALVE PARTS**  
571x4L Complete Valve Assembly (Locking)  
571x4N Complete Valve Assembly (Non-Locking)

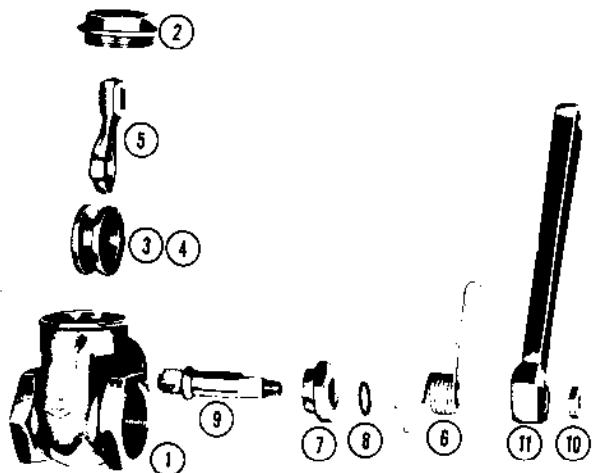

Ref. No.	Part No.	Description
	580x10	Complete Valve
1	B-41986-1	Body
2	B-41986-2	Cap
3	B-41986-3	Set { Male Disc Female Disc
4	B-41986-4	
5	B-41986-5	Lever
6	B-41986-6	Spring
7	B-41986-7	Bonnet
8	B-41986-8	"O" Ring
9	B-41986-9	Stem
10	B-41986-10	Handle Nut
11	B-41986-11	Lever Handle

**PANZITTA SALES & SERVICE**  
72 George Avenue  
Wilkes-Barre, PA 18705  
570-822-6720 800-822-6720  
[www.panzittasales.com](http://www.panzittasales.com)

**FIGURE 4-6. OIL VALVE PARTS**  
580 x 10 Gate Valve - 1 1/4" (Milwaukee) - Complete Assembly