

Models 15000 & 15002
Installation, Operation and Maintenance

PANZITTA SALES & SERVICE
72 George Avenue
Wilkes-Barre, PA 18705
570-822-6720 800-822-6720
www.panzittasales.com

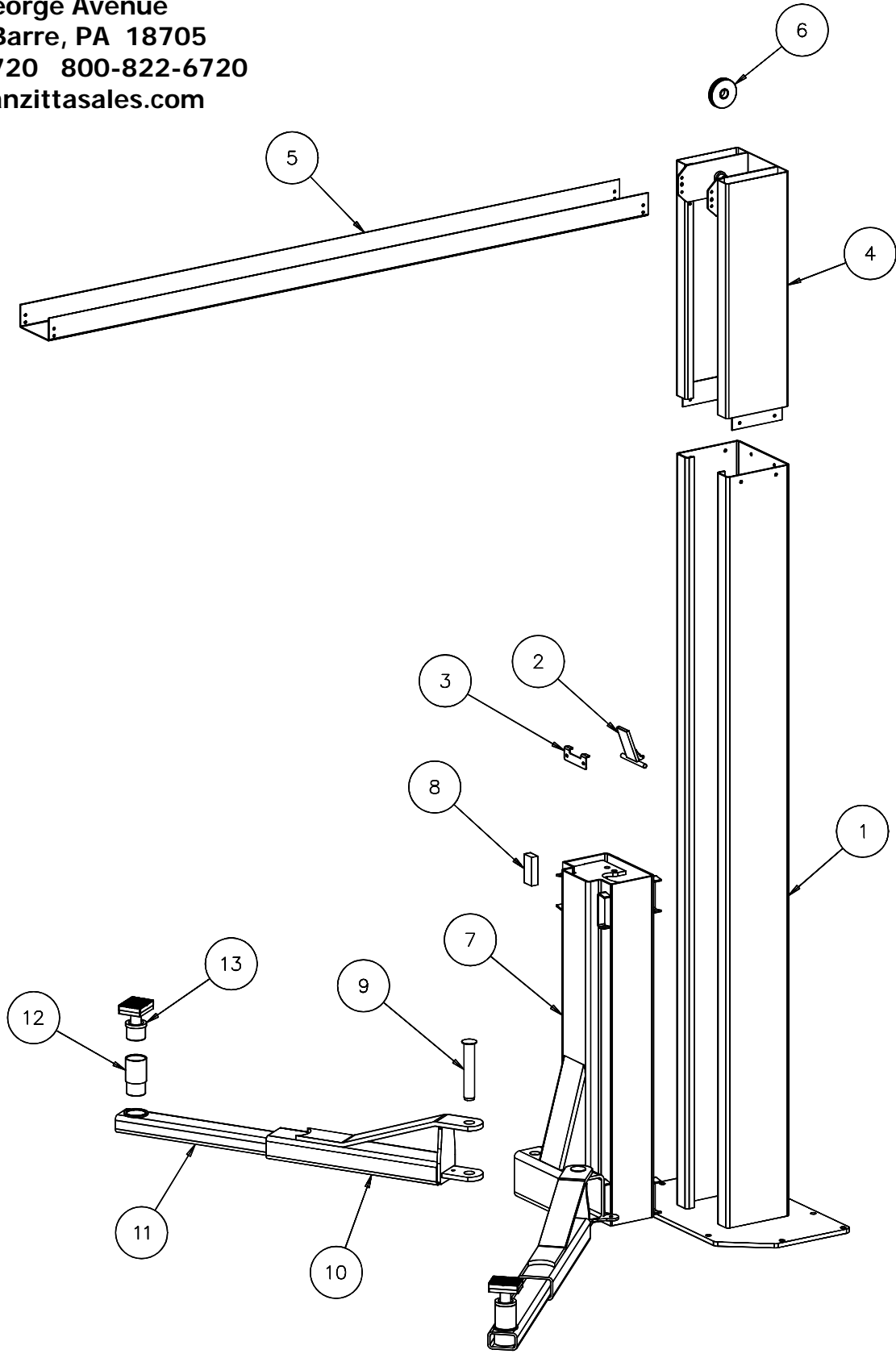

PARTS BREAKDOWN

MODEL 15000/15002

ITEM #	PART #	#/LIFT	DESCRIPTION
1	12025	1	POWER COLUMN WELD
	12026	1	IDLER COLUMN WELD
2	12033	2	LOCK WELD
	12037	2	LOCK RETAINER
	12073	4	5/16-18NC BUT.HD.CS X 1/2 LG
	37025	2	AIR CYLINDER ASSEMBLY
	12088	2	EXTENSION SPRING
	12102	2	COLUMN EXTENSION WELD (14'-6" O.A. Ht.)
4	12022	2	COLUMN EXTENSION WELD (16'-6" O.A. Ht.)
	31035	28	3/8-16NC X 1 HEX HD. CAP SCREW
	31036	28	3/8 FLAT WASHER
	31038	28	3/8-16NC HEX NUT
	12038	1	OVERHEAD WELD
5	12074	1	OVERHEAD SHUTOFF BAR ASSY
	12045	1	MERCURY SWITCH
	12019	2	SYNCHRONIZER CABLE ASSY (16'-6" O.A. Ht.)
	12100	2	SYNCHRONIZER CABLE ASSY (14'-6" O.A. Ht.)
6	31019	6	CABLE PULLEY
	31020	6	WASHER
	31021	6	RETAINER RING
7	12007	2	CARRIAGE WELD
8	12021	16	SLIDE BLOCK
9	12046	4	ARM PIN WELD
10	12049	4	FEMALE ARM WELD
11	12054	4	MALE ARM WELD
	12072	4	1/2-13NC SHCS X 5/8 LG
12	12069	4	EXTENSION (4")
	12068	2	EXTENSION (8")
13	12062	4	ADAPTER ASSEMBLY
	12071	2	ADAPTER RACK
	31305	4	3/8-16NC X 5/8 PHIL. PAN HD. SCREW
	12093	4	ARM RESTRAINT ASSEMBLY
	12085		POWER UNIT - SINGLE PHASE
	12089		POWER UNIT - THREE PHASE

Replace worn or broken parts with genuine CHALLENGER LIFTS INC. parts
 Contact your local Challenger Lifts Parts Distributor for pricing and availability
 (Call CHALLENGER LIFTS INC. (502) 625-0700 for the Parts Distributor in your area)