

ITEM	QTY	PART NO.	DESCRIPTION
1	16	028-161	#10-24 X 1 Pan Head Machine Screw
2	2	028-333	5/16 X 1/2 Shoulder Screw
3	1	03-0320	Lock Bar
4	4	03-0321	Ramp
5	1	03-0322	Cylinder Retainer
6	1	03-0323	Lock Release
7	1	03-0324	Lock Pivot
8	1	03-0325	Lock Release Bar
9	9	055-020	5/8-11 Bi-Way Hex Lock Nut
10	16	055-127	#10-24 Hex Nylock Nut
11	2	055-160	1/4-20 Hex Nylock Nut
12	8	061-181	3/16 X 3/4 Spring Pin
13	1	096-210	1/4 NPT Hex Nipple
14	4	10-0020	Rubber Pad
15	32	108-024	#10 SAE Washer
16	2	108-123	5/16 SAE Washer
17	2	50-0065	3/8-16 X 3/4 Hex Head Ser Flange Screw
18	8	50-0097	5/8-11 X 7 Hex Head Cap Screw, GR 8
19	1	50-0098	5/8-11 X 8 Hex Head Cap Screw, GR 8
20	10	54-0040	9/16 Retaining Ring (Push-On)
21	1	60-0065	Flow Control Valve
22	1	63-0018	Lift Cylinder
23	4	73-0767	Pivot Rod
24	8	74-0182	Roller Tube
25	5	31058	Anchor Bolt, 3/4" dia x 5 1 1/2" lg (not shown)

Model 67000 Installation, Operation & Maintenance

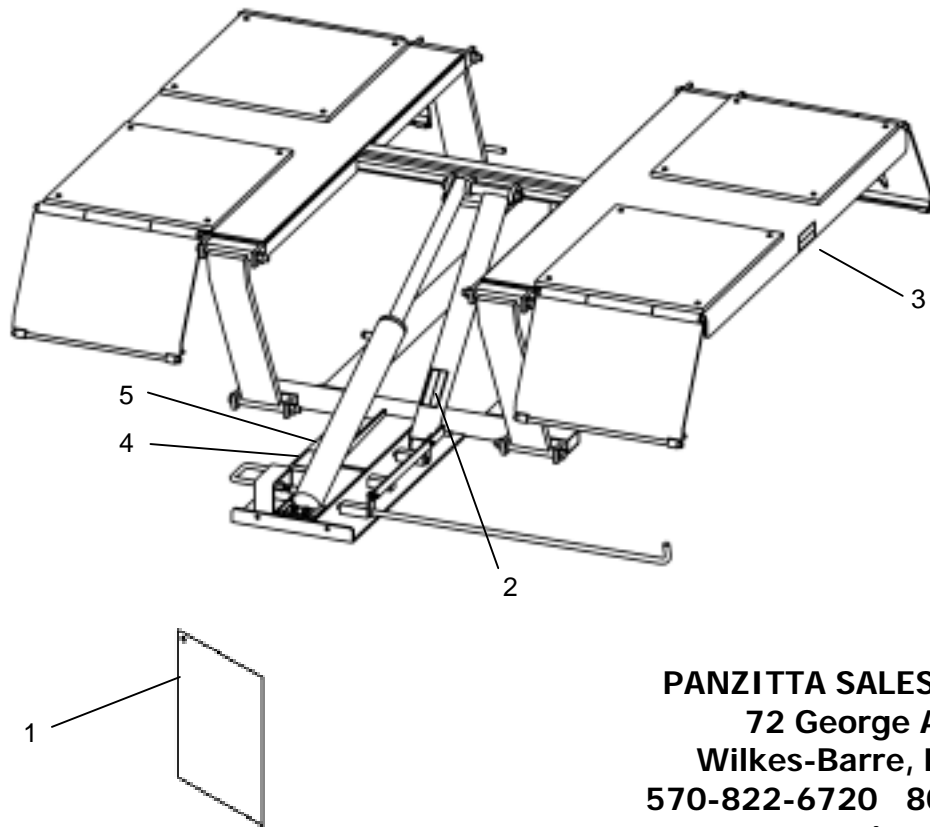

PANZITTA SALES & SERVICE
 72 George Avenue
 Wilkes-Barre, PA 18705
 570-822-6720 800-822-6720
 www.panzittasales.com



80-0147



80-0148



80-0150



80-0151

ITEM	QTY	PART NO.	DESCRIPTION
1	1	80-0145	Instruction Placard
2	1	80-0147	Caution Decal
3	2	80-0148	Warning Decal
4	1	80-0150	Caution Decal
5	1	80-0151	Warning Decal

PANZITTA SALES & SERVICE
 72 George Avenue
 Wilkes-Barre, PA 18705
 570-822-6720 800-822-6720
 www.panzittasales.com

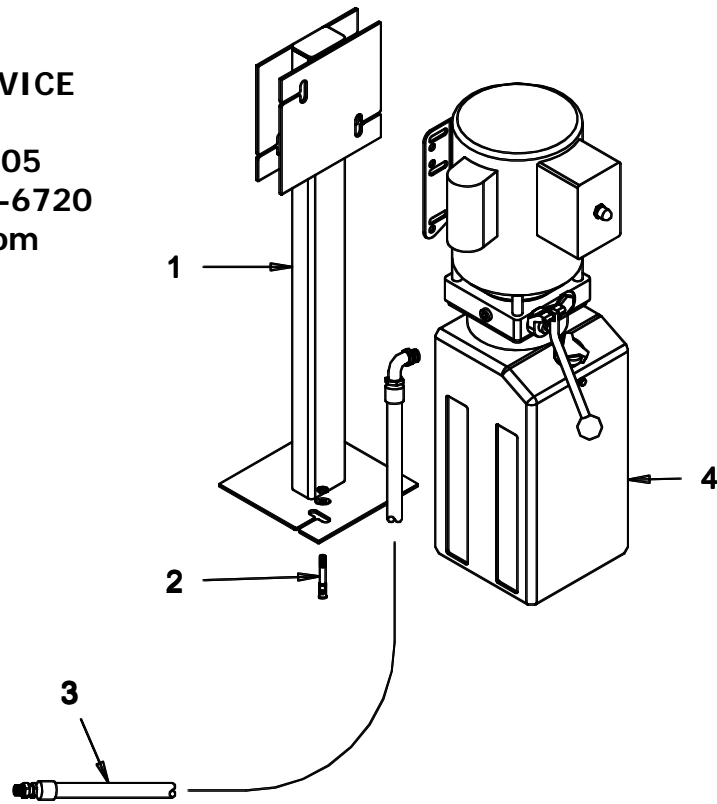

ITEM	QTY	PART NO.	DESCRIPTION
1	1	485389	Power Unit Stand
2	1	427932	Anchor Bolt, 3/8 x 2 1/4" lg
3	2	67004/67004-30	Hydraulic Hose 20'lg / Hydraulic Hose 30'lg
4	1	428730	AC., Power Unit 60Hz