

LIFT PARTS
LFS9

PANZITTA SALES & SERVICE
72 George Avenue
Wilkes-Barre, PA 18705
570-822-6720 800-822-6720
www.panzittasales.com

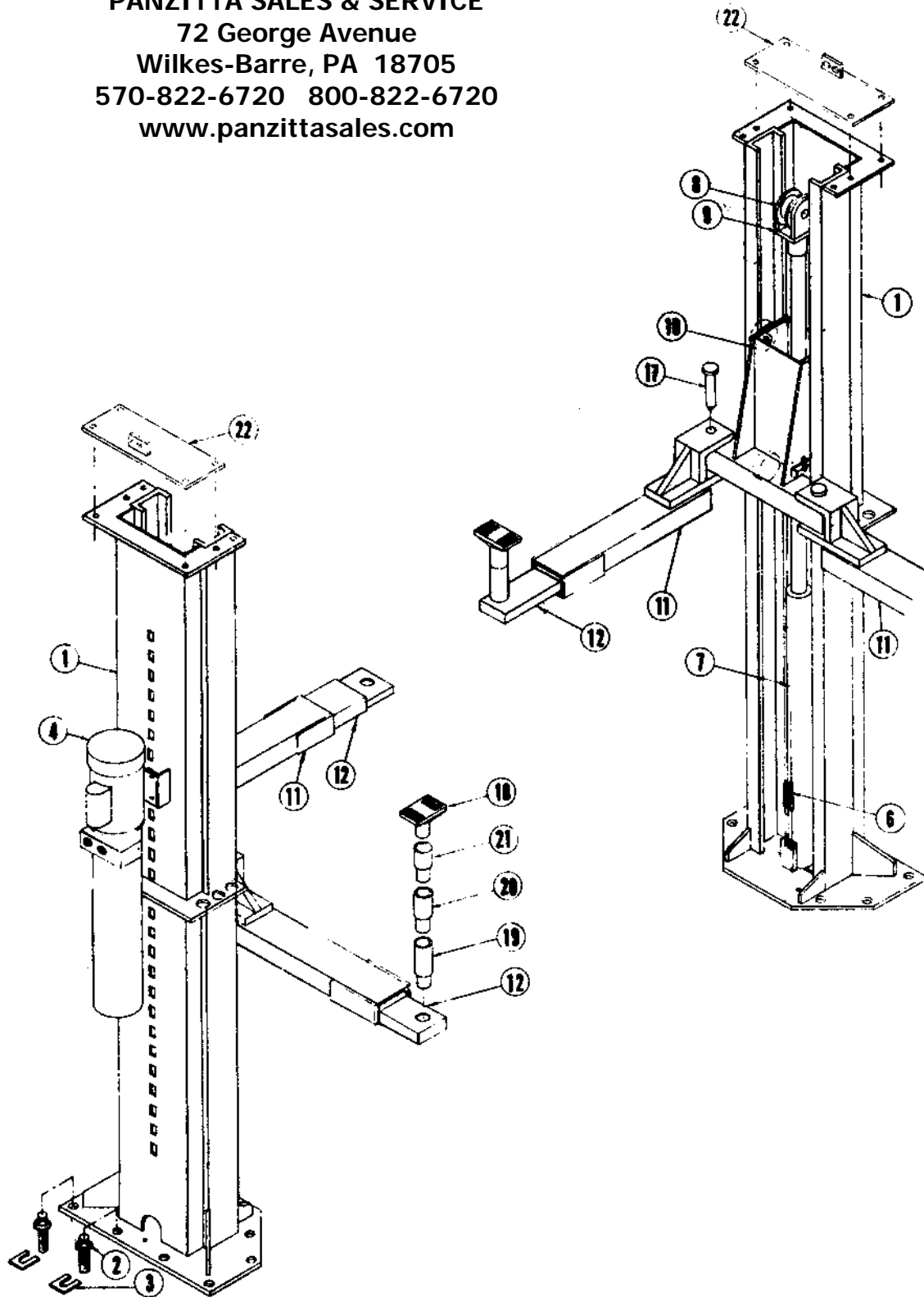

LIFT PARTS
LFS9

Code	Part Name	Qty.	LFS9
1	Post Structure	2	82712
2	Anchor Bolt 3/4 x 5	16	80362
3	Shim Kit (Under Posts)	1	80589
4	Power Unit Ass'y. 10 (See Breakdown WE)	1	82959
OR 4	Power Unit Ass'y. 10 (See Breakdown MTE)	1	82965
	Hex Screw 5/16-18NC x 7/8	4	100198
	Lock Washer 5/16	4	100159
	Hex Nut 5/16-18NC	4	100102
#	Connecting Body 10 3-Wire Ground	1	80136
6	Chain	2	82156
	Soc. Hd. Cap Screw (Sp.) 5/16-18NC x 1 3/4	2	81185
	Soc. Hd. Cap Screw (Sp.) 5/16-18NC x 2 3/4	2	81907
	Hex Nut - Nylock 5/16-18NC	4	80064
7	Hydraulic Cylinder - Slave	1	82081
7#	Hydraulic Cylinder - Master	1	82080
	Flat Washer (Shim) 2 OD	6	100143
	HFHSL Screw (Mt. Cyl.) 3/8-16NC x 3/4 Gr. 5	4	100240
	Seal Kit - Cessna Cyl. (Replacement) Slave	-	81799
	Seal Kit - Cessna Cyl. (Replacement) Master	-	81798
8	Roller Assembly - Cylinder Consists Of:	2	82716
	1 - 82717 Roller		
	2 - 80171 Bearing		
9	Cylinder End Structure	2	81612
	Spacer - Roller	2	80227
	Pin - Cylinder End	2	81822
	Retaining Ring - Wide 3/4	4	80864
10	Carriage Assembly (See Breakdown)	2	82160
11	Lift Arm Structure	4	82301
12	Arm Extension Structure	4	82304
17	Pin Structure 1 Dia.	4	81885
18	Pad	4	81690
19*	5" Extension Structure	4	81691
20*	3 1/2" Extension Structure (Optional)	4	81692
21*	2 5/8" Extension Structure	4	81693
22	Cover Structure	2	82231
	Hex Screw 1/2-13NC x 1 1/4 Gr. 5	8	100010
	HFHSL Nut 1/2-13NC	8	100039
#	Decal "BEN PEARSON"	2	82345
#	Decal "LFS"	2	82357
#	Decal "9"	2	82348
	OPTIONAL		
	Power Unit Ass'y. Universal 30 WE	1	82960
Or	Power Unit Ass'y. Universal 30 MTE	1	82966
	Connecting Body 30 - 4 Wire Ground	1	80140
	3 1/2" Extension Structure	4	81692
	Lift Pad Assembly - Rubber - Includes:	4	82591
	1 - 82361 Lift Pad Structure		
	1 - 82365 Rubber Pad & Hardware		
#	NOT SHOWN		
*	EXTENSIONS ARE FOR LEVELING AND STABILIZING VEHICLE ONLY! LOAD MUST BE BALANCED ON ARMS.		

PANZITTA SALES & SERVICE
72 George Avenue
Wilkes-Barre, PA 18705
570-822-6720 800-822-6720
www.panzittasales.com

LIFT PARTS
LFS09

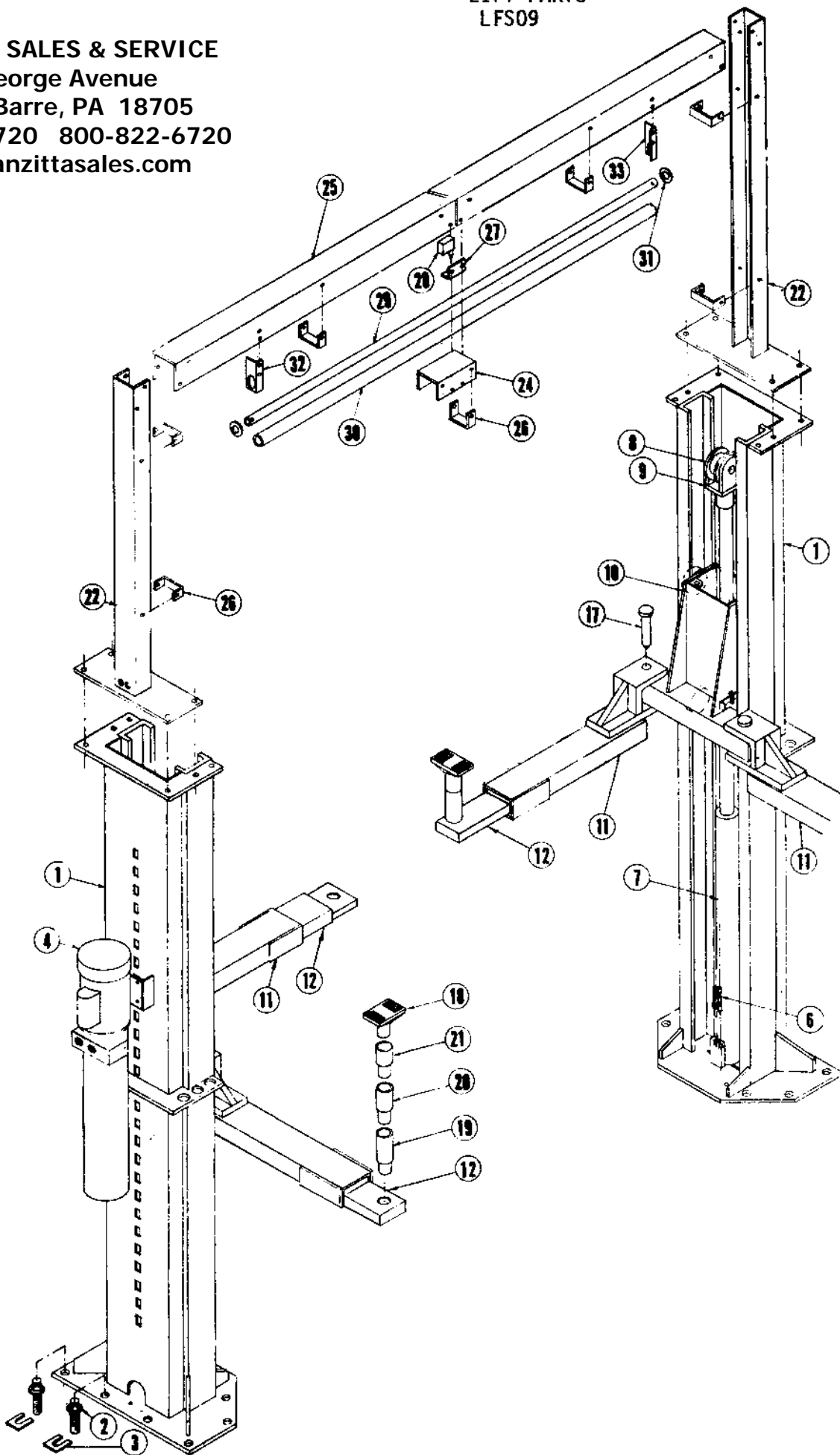

LIFT PARTS
LFS09

Code	Part Name	Qty.	LFS09
1	Post Structure	2	82712
2	Anchor Bolt 3/4 x 5	16	80362
3	Shim Kit (Under Posts)	1	80589
4	WE Power Unit & Wiring Ass'y. 1Ø OR	1	83011
4	MTE Power Unit & Wiring Ass'y. 1Ø (See Breakdown)	1	82971
	Hex Screw 5/16-18NC x 7/8	4	100198
	Lock Washer 5/16	4	100159
	Hex Nut 5/16-18NC	4	100102
#	Connecting Body - 1Ø 3-Wire Ground	1	80136
6	Chain	2	82156
	Soc. Hd. Cap Screw (Sp.) 5/16-18NC x 1 3/4	2	81185
	Soc. Hd. Cap Screw (Sp.) 5/16-18NC x 2 3/4	2	81907
	Hex Nut - Nylock 5/16-18NC	4	80064
7	Hydraulic Cylinder - Slave	1	82081
7#	Hydraulic Cylinder - Master	1	82080
	6- 100143 Flat Washer (Shim)		
	HFHSL Screw (Mt. Cyl.) 3/8-16NC x 3/4 Gr. 5	4	100240
	Seal Kit - Cessna Cyl. (Replacement - Slave)	1	81799
	Seal Kit - Cessna Cyl. (Replacement - Master)	1	81798
8	Roller Assembly - Cylinder Consists Of:	2	82716
	1 - 82717 Roller		
	2 - 80171 Bearing		
9	Cylinder End Structure	2	81612
	Spacer - Roller	2	80227
	Pin - Cylinder End	2	81822
	Retaining Ring - Wide 3/4	4	80864
10	Carriage Assembly (See Breakdown)	2	82160
11	Lift Arm Structure	4	82301
12	Arm Extension Structure	4	82304
17	Pin Structure 1 Dia.	4	81885
18	Pad	4	81690
19*	5" Extension Structure	4	81691
20*	3 1/2" Extension Structure (Optional)	4	81692
21*	2 5/8" Extension Structure	4	82693
22	Vertical Structure - Post Extension	2	82233
	Hex Screw (Ext. to Post) 1/2-13 NC x 1 1/4 Gr. 5	8	100010
	HFHSL Nut 1/2-13NC	8	100039
24	Channel - Tie	1	82186
25	Channel - Horizontal	2	82187
	HFHSL Screw (Channel to 5/16-18 x 3/4	16	100234
	HFHSL Nut Extensions & Tie) 5/16-18 NC	16	100237
#	Not Shown		
*	EXTENSIONS ARE FOR LEVELING AND STABILIZING VEHICLE ONLY! LOAD MUST BE BALANCED ON ARMS!		

LIFT PARTS
LFS09

Code	Part Name	Qty.	Part No.
26	Strap - Retaining	7	82217
	HFHSL Screw 5/16-18NC x 3/4 Gr. 5	12	100234
	HFHSL Nut 5/16-18NC	12	100237
27	Angle - Switch Support	1	81864
28	Micro Switch - Push Button	1	80282
	Cover - Switch	1	81910
29	Pipe - Bumper	1	81862
30	Tubing - Bumper	1	81863
31	Flat Washer 1 5/32 ID	2	100224
	Hex Screw 5/16-18 NC x 1 1/2 Gr. 5	2	81483
	Lock Washer 5/16	2	100159
	Hex Nut 5/16-18 NC	2	100102
32	LH Angle Support	1	81860
33	RH Angle Support	1	81861
	HFHSL Screw 5/16-18 NC x 3/4 Gr. 5	4	100234
	HFHSL Nut 5/16-18 NC	4	100237
#	Decal "BEN PEARSON"	2	82345
#	Decal "LFS"	2	82357
#	Decal "0"	2	82377
#	Decal "9"	2	82348
OPTIONAL			
	Power Unit & Wiring Ass'y. Universal 3Ø (See Brk.Down)	1	
	Connecting Body 3Ø - 4 Wire Ground	1	80140
	3 1/2" Extension Structure	4	81692
	Lift Pad Ass'y. - Rubber - Includes:	4	82591
	1 - 82361 Lift Pad Structure		
	1 - 82365 Rubber Pad & Hardware		
<p>PANZITTA SALES & SERVICE 72 George Avenue Wilkes-Barre, PA 18705 570-822-6720 800-822-6720 www.panzittasales.com</p>			

AIR LINE LAYOUT
LFS - LFSO

PANZITTA SALES & SERVICE
72 George Avenue
Wilkes-Barre, PA 18705
570-822-6720 800-822-6720
www.panzittasales.com

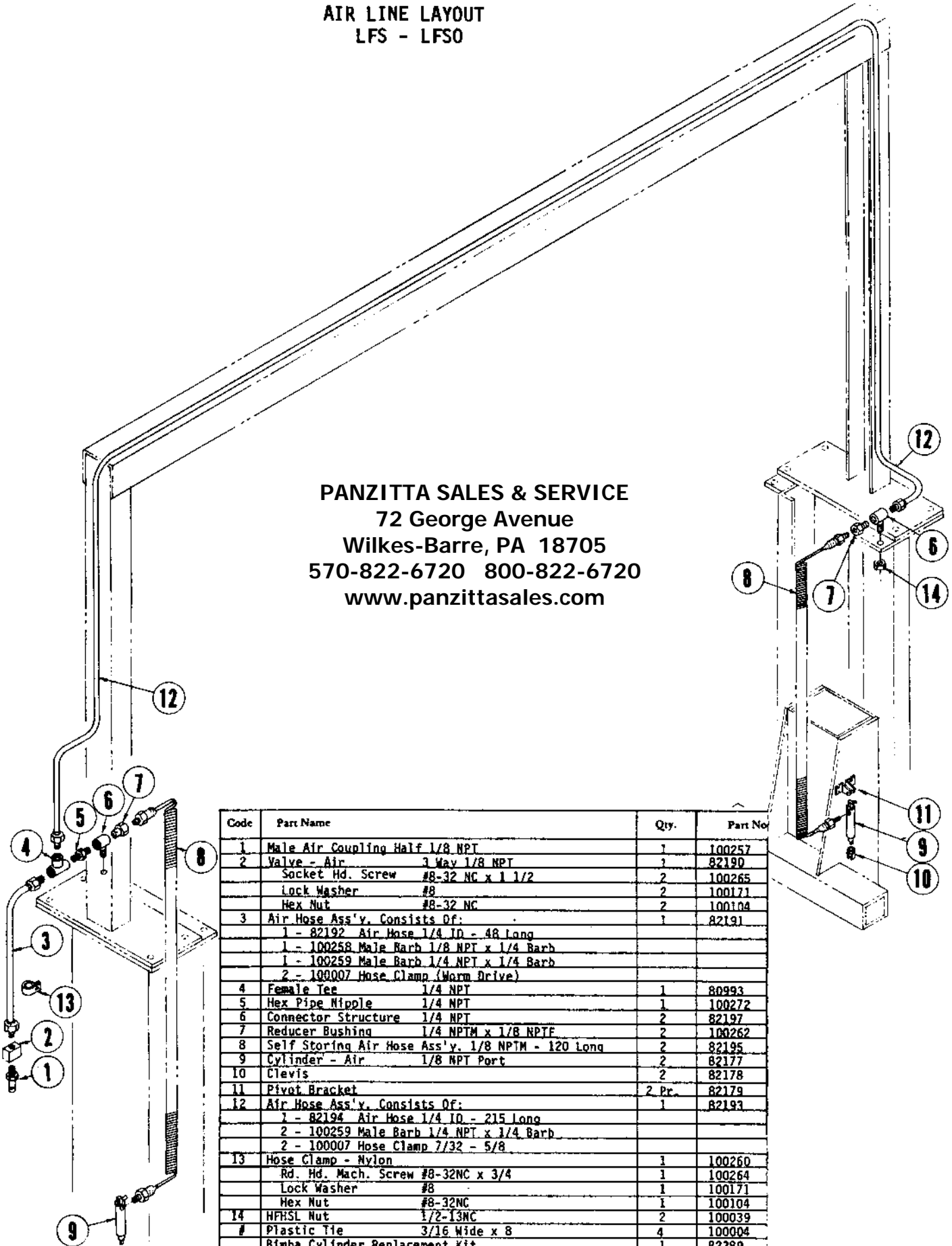

Code	Part Name	Qty.	Part No.
1	Male Air Coupling Half 1/8 NPT	1	100257
2	Valve - Air 3 Way 1/8 NPT	1	82190
	Socket Hd. Screw #8-32 NC x 1 1/2	2	100265
	Lock Washer #8	2	100171
	Hex Nut #8-32 NC	2	100104
3	Air Hose Ass'y. Consists Of:	1	82191
	1 - 82192 Air Hose 1/4 ID - 48 Long		
	1 - 100258 Male Barb 1/8 NPT x 1/4 Barb		
	1 - 100259 Male Barb 1/4 NPT x 1/4 Barb		
	2 - 100007 Hose Clamp (Warm Drive)		
4	Female Tee 1/4 NPT	1	80993
5	Hex Pipe Nipple 1/4 NPT	1	100272
6	Connector Structure 1/4 NPT	2	82197
7	Reducer Bushing 1/4 NPTM x 1/8 NPTF	2	100262
8	Self Storing Air Hose Ass'y. 1/8 NPTM - 120 Long	2	82195
9	Cylinder - Air 1/8 NPT Port	2	82177
10	Clevis	2	82178
11	Pivot Bracket	2 Pr.	82179
12	Air Hose Ass'y. Consists Of:	1	82193
	1 - 82194 Air Hose 1/4 ID - 215 Long		
	2 - 100259 Male Barb 1/4 NPT x 1/4 Barb		
	2 - 100007 Hose Clamp 7/32 - 5/8		
13	Hose Clamp - Nylon	1	100260
	Rd. Hd. Mach. Screw #8-32NC x 3/4	1	100264
	Lock Washer #8	1	100171
	Hex Nut #8-32NC	1	100104
14	HFHSL Nut 1/2-13NC	2	100039
#	Plastic Tie 3/16 Wide x 8	4	100004
	Bimba Cylinder Replacement Kit	1	82389

HYDRAULIC LAYOUT
LFS9 - LFS09

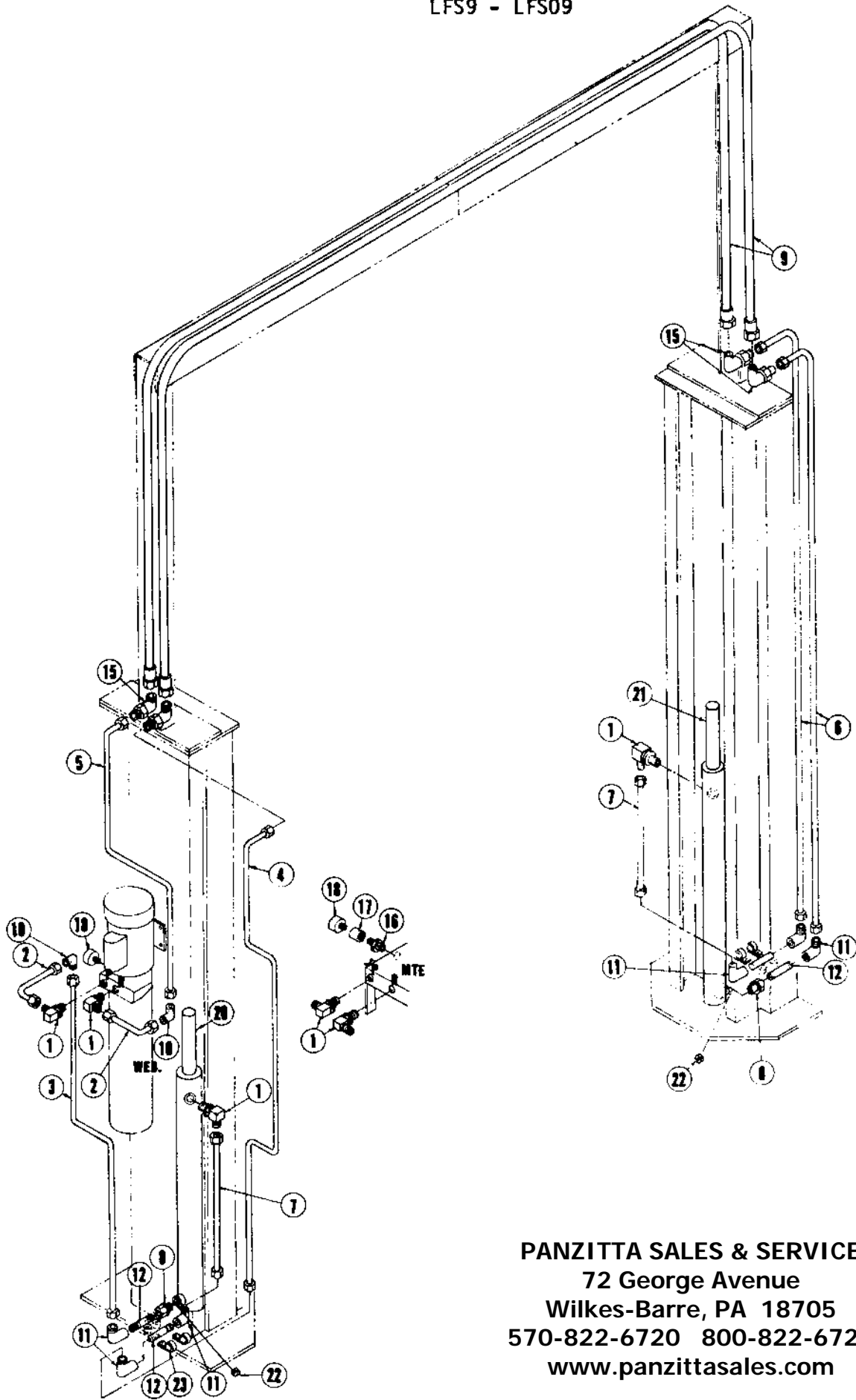

PANZITTA SALES & SERVICE
72 George Avenue
Wilkes-Barre, PA 18705
570-822-6720 800-822-6720
www.panzittasales.com

PANZITTA SALES & SERVICE
72 George Avenue
Wilkes-Barre, PA 18705
570-822-6720 800-822-6720
www.panzittasales.com

CARRIAGE ASSEMBLY
LFS - LFS0

