

PANZITTA SALES & SERVICE
72 George Avenue
Wilkes-Barre, PA 18705
570-822-6720 800-822-6720
www.panzittasales.com

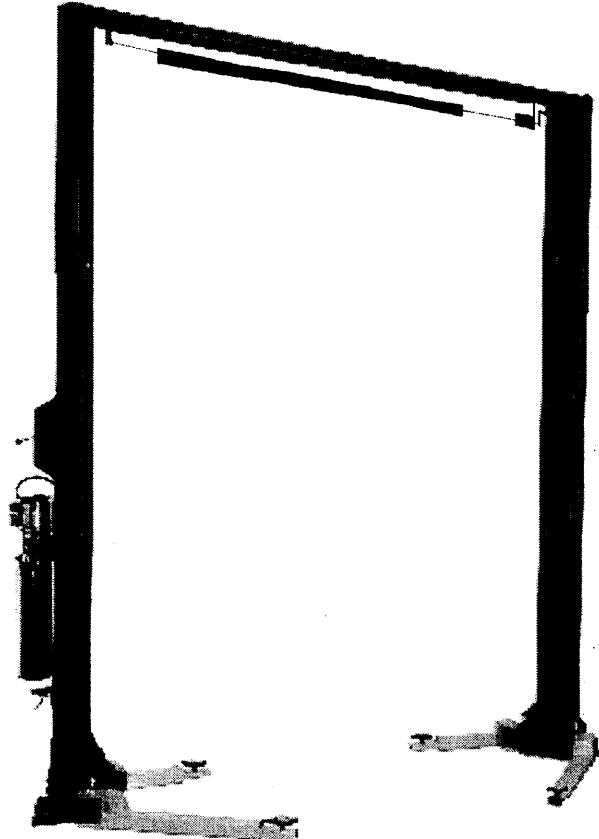

9,000 LB. SYMMETRIC 2 POST
S29TS □ □ - R/B/M, 1/3

READ and SAVE THIS
INSTRUCTION MANUAL

DEC 2001 6-2673

8 PARTS MANUAL

8.1 LIFT ASSEMBLY

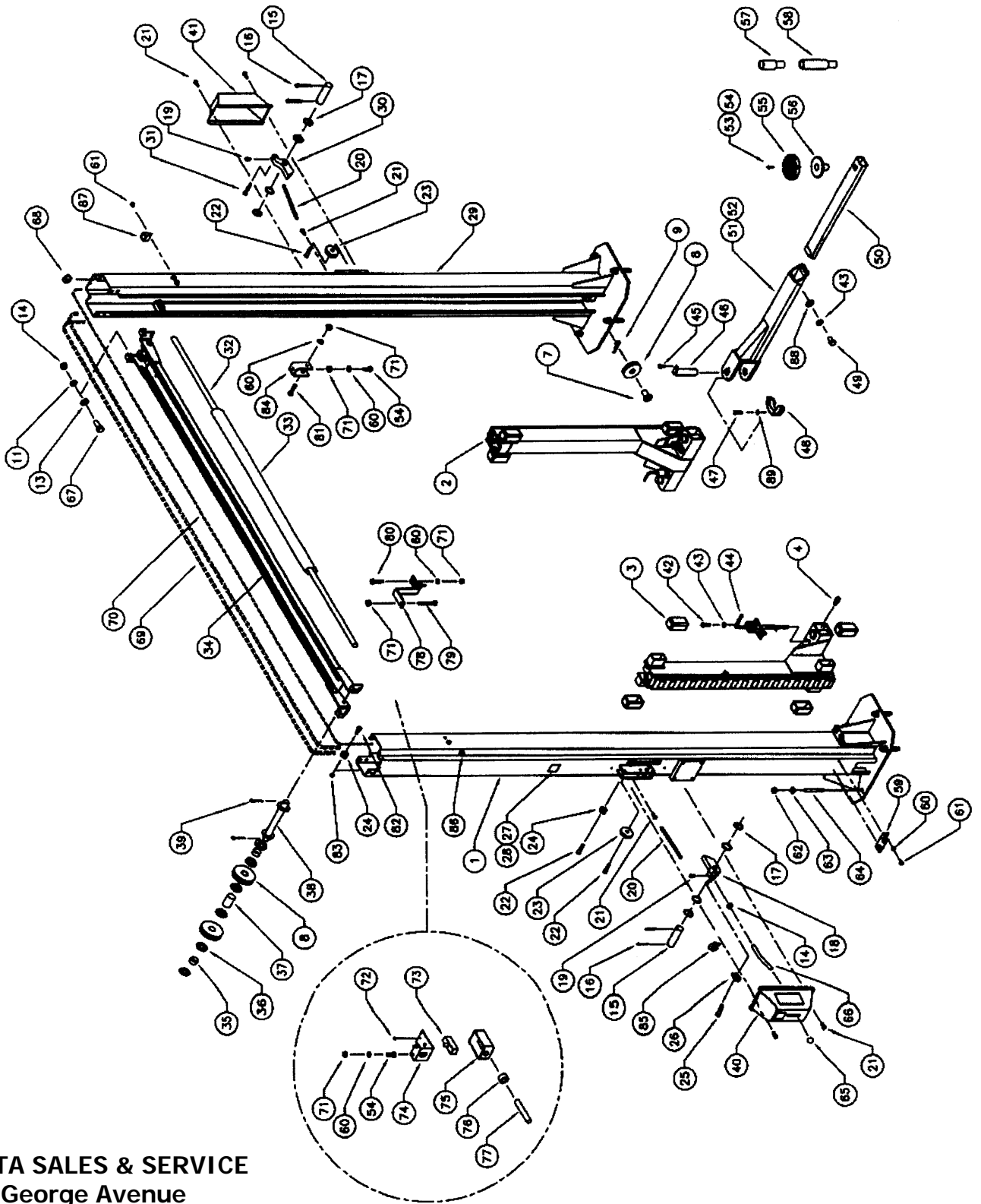

PANZITTA SALES & SERVICE
72 George Avenue
Wilkes-Barre, PA 18705
570-822-6720 800-822-6720
www.panzittasales.com

8.2 LIFT ASSEMBLY PARTS LIST

ITEM	QTY	DESCRIPTION	PART #
1	1	TOWER WELDMENT, POWER SIDE	4-0767
2	2	CARRIAGE WELDMENT	4-0766
3	8	GLIDE BEARING	2-0772
4	4	GREASE NIPPLE	6-0000
7	2	PIN, CABLE EQUALIZATION	1-1887
8	6	2-POST PULLEY	1-1898
9	2	HITCH PIN, 1/8" DIA	6-1841
11	8	LOCKWASHER, 1/2"ID	6-0059
13	8	FLAT WASHER, 1/2"ID SAE	6-0248
14	13	HEX NUT, 1/2"-13UNC	6-0035
15	2	SAFETY PIN	1-0938
16	4	COTTER PIN, 1/8"DIA. x 1"LG.	6-0267
17	8	FLAT WASHER, 51/64"ID x 1"OD x 1/16"THK.	6-0808
18	1	SAFETY DOG WELDMENT, POWER SIDE	2-1901
19	4	SELF TAPPING SCREW, #10 X 3/8" LG.	6-0169
20	2	SAFETY SPRING	1-1115
21	6	SELF TAPPING SCREW, #12 x 1/2"LG.	6-1134
22	3	SHOULDER BOLT, 3/8"DIA. x 1"LG.	6-0206
23	2	SAFETY PULLEY	1-0415
24	3	SAFETY CABLE PULLEY	1-1116
25	1	SHOULDER BOLT, 3/8" x 1 1/2" LG.	6-0801
26	1	THIMBLE, 5/32"	6-2074
27	1	CAPACITY DECAL	6-1767
28	1	SERIAL PLATE	6-1111
29	1	TOWER WELDMENT, SLAVE SIDE	4-0768
30	1	SAFETY DOG, SLAVE SIDE	2-0872
31	1	SHOULDER BOLT, 3/8"DIA. x 1 1/2"LG.	6-0801
32	1	ACTUATOR BAR	1-1439
33	1	FOAM GUARD	6-1404
34	1	CROSSMEMBER WELDMENT	2-1281
35	4	CROSSMEMBER PULLEY PIPE, 1/2"LG.	1-1623
36	16	FLAT WASHER, 3/4"ID	6-0738
37	2	CROSSMEMBER PULLEY PIPE, 1 3/4"LG.	1-1626
38	2	CROSSMEMBER PULLEY SHAFT	2-1251
39	4	COTTER PIN, 1/8"DIA. x 1 1/2"LG.	6-0978
40	1	SAFETY COVER cw/DECALS, POWER SIDE	0-0204
41	1	SAFETY COVER cw/DECALS, SLAVE SIDE	0-0203
42	8	SOCKET HEAD CAP SCREW, 3/8" X 1" LG.	6-2048
43	12	LOCKWASHER, 3/8" ID	6-0058
44	4	ARM LOCK ASSEMBLY	1-2038
45	4	HEX BOLT, 5/16"-18UNC x 3/4" LG.	6-0423
46	4	ARM PIN	2-1594
47	4	HEX BOLT, 5/16"-18UNC x 1 1/4" LG.	6-2059
48	4	ARM LOCK GEAR	1-2044
49	4	HEX BOLT, 3/8UNCx3/4"LG.	6-0030
50	4	INNER ARM WELDMENT	3-0761

PANZITTA SALES & SERVICE
72 George Avenue
Wilkes-Barre, PA 18705
570-822-6720 800-822-6720
www.panzittasales.com

ITEM	QTY	DESCRIPTION	PART #
51	4	OUTER ARM WELDMENT	3-0850
52	4	LOCKING ARM ASSEMBLY cw/ARM LOCK PIN	4-0950-6
53	4	STACK PAD ASSEMBLY	1-2045
54	7	HEX BOLT, 1/4"-20UNC x 3/4" LG.	6-0178
55	4	RUBBER PAD	6-2050
56	4	STACK PAD WELDMENT	1-2030
57	4	STACK PAD ADAPTER, 3"	1-1993
58	4	STACK PAD ADAPTER, 6"	2-1580
59	2	STACK PAD ADAPTER HOLDER	1-2012
60	10	LOCKWASHER, 1/4" ID	6-0056
61	10	ROUND HEAD SCREW, 1/4"-20UNC x 3/8" LG.	6-1353
62	10	HEX NUT, 3/4"-10UNC	6-0737
63	10	FLAT WASHER, 3/4"ID	6-0738
64	10	WEDGE ANCHOR, 3/4"-10UNC x 5 1/2"LG.	6-1379
65	1	PLASTIC KNOB	6-1135
66	1	SAFETY RELEASE HANDLE	1-1113
67	8	HEX BOLT, 1/2"-13UNC x 1 1/4" LG.	6-0046
68	3	RUBBER GROMMET	6-1507
69	2	EQUALIZING CABLE	1-1473
70	1	SAFETY RELEASE CABLE	1-2058
71	7	HEX HD. NUT 1/4"NC	6-0032
72	2	6/32 SCREW (ELECTRICAL BOX)	6-1466
73	1	MICROSWITCH	6-0916
74	1	LIMIT SWITCH MTG. BRACKET	2-1143
75	1	ELECTRICAL UTILITY BOX	6-1403
76	1	CABLE CONNECTOR	6-1133
77	1	ELEC. CABLE 12/3 x 117"LG.	6-1173
78	1	ACTUATOR EXTENSION	1-1379
79	1	HEX HD. BOLT 1/4"NC x 2"LG.	6-0741
80	2	HEX HD. BOLT 1/4"NC x 1 1/4"LG.	6-0027
81	1	HEX HD. BOLT 1/4"NC x 1 1/2"LG.	6-0205
82	2	SHOULDER BOLT, 3/8"DIA. x 5/8"LG.	6-0069
83	2	HEX NUT, 5/16"-18UNC	6-0294
84	1	ACTUATOR MTG. BRACKET	1-1378
85	2	WIRE ROPE CLIP, 1/16"	6-2060
86	3	ELECTRICAL CABLE CLIP, 5/8" ID	6-1759
87	6	TUBE CLAMP, 1/2"	6-0536
88	4	FLATWASHER, 3/8"ID SAE	6-0062
89	8	FLATWASHER, 5/16"ID	6-0295

8.3 HYDRAULIC SYSTEM

PANZITTA SALES & SERVICE
72 George Avenue
Wilkes-Barre, PA 18705
570-822-6720 800-822-6720
www.panzittasales.com

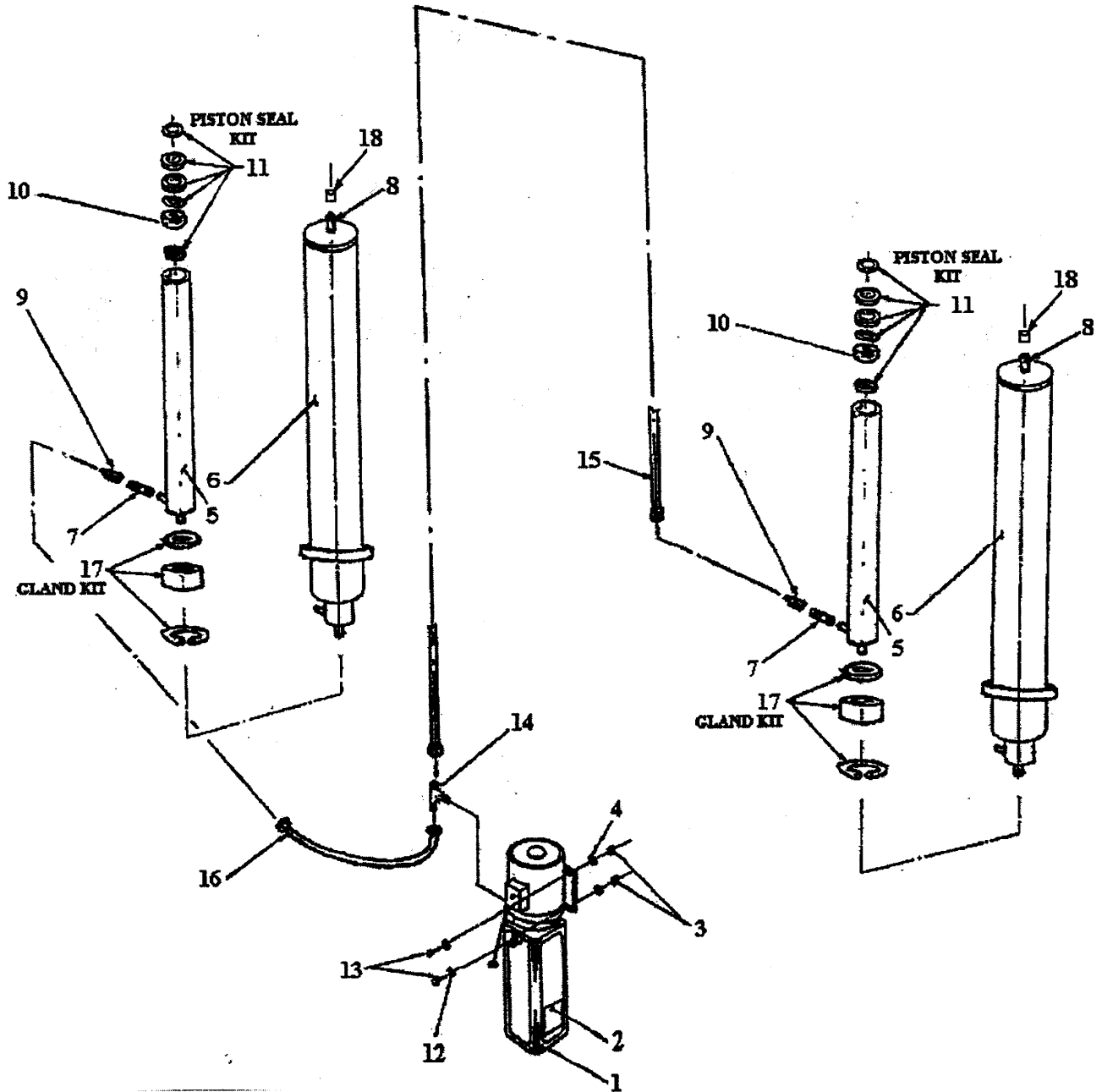

8.4 HYDRAULIC SYSTEM PARTS LIST

ITEM	QTY	DESCRIPTION	PART #
1	1	POWER PACK, 208-230V, 1PH	6-2055
		POWER PACK, 208-230V, 3PH	6-2665
2	1	"LIFT OPERATION" DECAL	6-1639
3	4	HEX NUT, 5/16"-18UNC	6-0294
4	4	LOCK WASHER, 5/16" I.D.	6-0674
5	2	PISTON ROD 1 1/4" O.D. x 1/4" W x 72 11/16 LG.	1-1469
6	2	CYLINDER TUBE MACHINED	1-1465
7	2	MALE NIPPLE, 1/4" NPT	6-2059
8	2	1/8" NPT TO 1/4" JIC	6-0280
9	2	FLOW CONTROL	6-1510
10	2	PISTON	1-1467
11	2	PISTON SEAL KIT	0-0337
12	4	FLAT WASHER, 5/16" I.D.	6-0295
13	4	HEX BOLT, 5/16"-18UNC x 1" LG.	6-0293
14	1	BRANCH TEE	6-1506
15	1	HYDRAULIC HOSE (LONG)	1-2040
16	1	HYDRAULIC HOSE (SHORT)	2-1230
17	2	GLAND KIT	0-0338
18	2	1/4" JIC CAP	6-1884
	*	CYLINDER ASSEMBLY (INCL. FLOW CONTROL)	3-0621
<i>3 PH POWERPACK INCLUDES THE FOLLOWING (NOT SHOWN)</i>			
*	1	CONTACTOR BOX (REMOVE JUMPER & WIRE FOR 3PH)	6-1575
*	1	CONTACTOR BRACKET	2-1130
*	1	COVER PLATE	1-1369
*	2	HEX BOLT, 1/4"-NC x 1" LG	6-0008
*	4	LOCKWASHER, 1/4"	6-0056
*	2	HEX NUT, 1/4"-NC	6-0032
*	2	STRAIN RELIEF	6-0094
*	2FT	CABLE, 14/4	8-0287

8.5 POWER PACK:

PANZITTA SALES & SERVICE
 72 George Avenue
 Wilkes-Barre, PA 18705
 570-822-6720 800-822-6720
 www.panzittasales.com

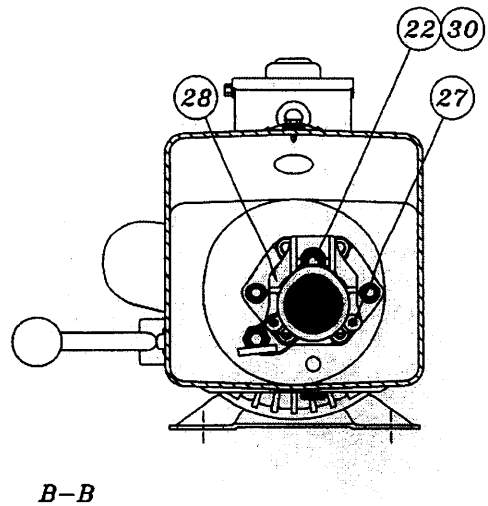
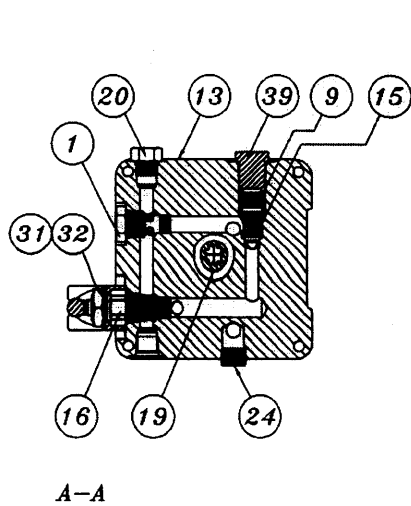
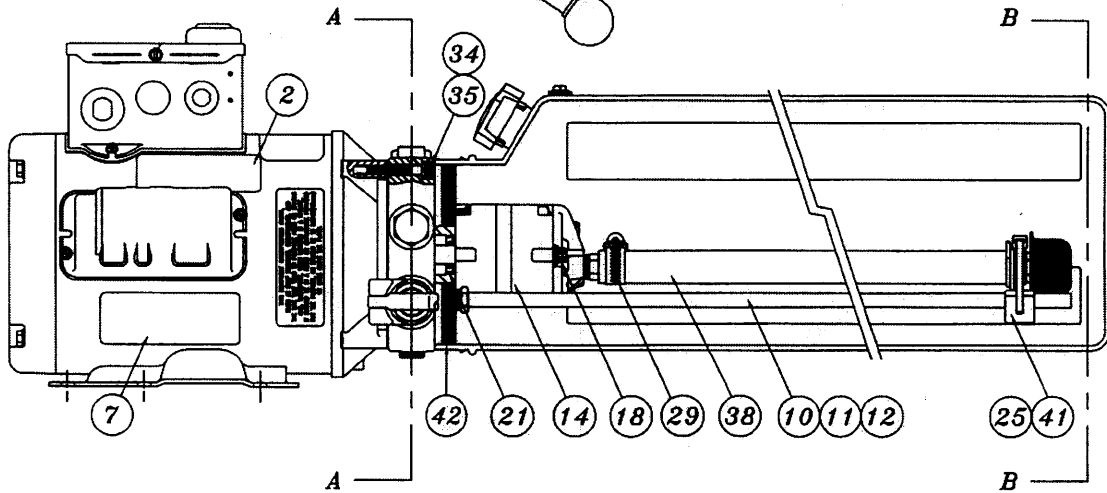
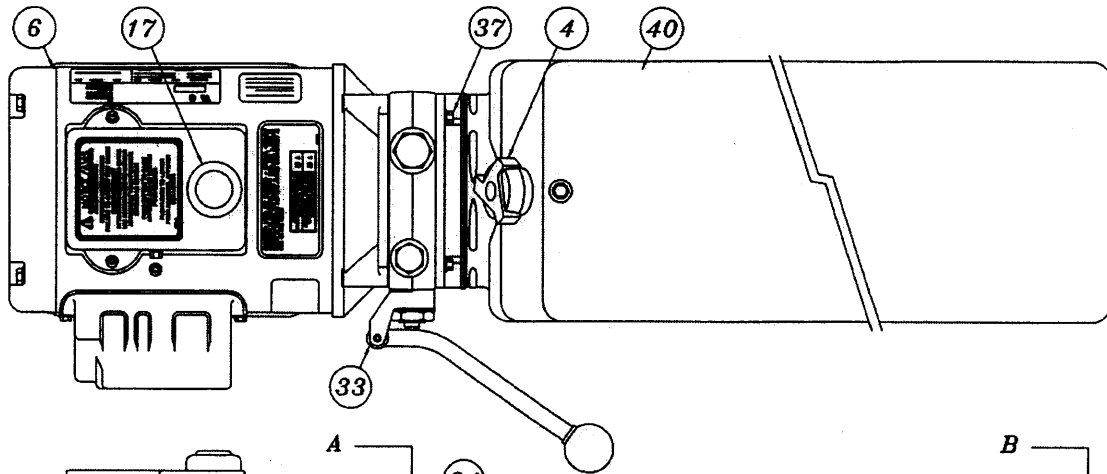

8.6 POWER PACK PARTS LIST:

#6-2055 (AB-1381) 208-230V/1PH/60Hz

#6-2665 (AD-1044) 208-230V/1PH/60Hz

ITEM	QTY.	DESCRIPTION	PART #
1	1	VALVE CARTRIDGE CHECK	6-1087
2	1	LABEL INSTALLATION AUTOHOIST	6-2136
4	1	BREATHER CAP & BLADDER	6-1376
6	1	MOTOR AC 208-230V. 2HP/1PH/60Hz, BLK	6-2139
	1	MOTOR AC 208-230V. 2HP/3PH/60Hz, BLK	6-1079
7	1	LABEL WARNING AUTOHOIST	6-2149
9	1	SPRING 0.480" x 0.063" x 0.42" COMP	6-2151
10	1	RETURN HOSE 3/8" OD x 21.5"	6-2152
11	1	COMPRESSION TUBE NUT	6-2153
12	1	COMPRESSION TUBE SLEEVE	6-2154
13	1	ENDHEAD UNIVERSAL AUTOHOIST	6-2155
14	1	PUMPASSY 2.5 CC/REV. SHORT SPLINE	6-1958
15	1	RELIEF ASSEMBLY FIXED 190 BAR	6-1319
16	1	VALVE CARTRIDGE RELEASE MANUAL	6-0880
17	1	WIRING ASSEMBLY AC 1PH FENNER	6-2156
18	2	BOLT 5/16"-24 x 3.00" TORX G8	6-1090
19	1	COUPLING SAE 9T-20/40 1.260"	6-0774
20	1	PLUMBING PLUG 9/16" SAE	6-2157
21	1	SEAL SHAFT 0.500" x 1.00" x 0.25"	6-2158
22	1	WASHER 0.338" x 0.625" x 0.060" STEEL	6-2159
24	1	PLUMBING PLUG 3/8" NPT	6-2161
25	1	PLUMBING MAGNET	6-2162
27	2	SCREW TAPTITE M6 x 1.0 12MM TORX	6-2164
28	1	COVER ASSY SUCTION	6-2165
29	1	PLUMBING CLAMP HOSE ADJ. INLET	6-2166
30	1	BOLT 5/16"-18 x 1.00" SHCS	6-1392
31	1	NUT 3/4"-16 x 1" HEX x 0.250" STEEL	6-2167
32	1	WASHER 3/4" INT. TOOTH LOCK	6-2168
33	1	BRACKET - HANDLE ASSY REL BLACK	6-0776
34	4	BOLT M6 x 1.0 35MM SOC HD	6-2169
35	4	WASHER 1/4" LOCK HI-COLLAR	6-2170
37	4	BOLT #12-24 x 0.50" HEX WSHRHD	6-1091
38	1	PLUMBING ASSY INLET 17.24 (3)	6-0786
39	1	RELIEF VALVE CAP ASSEMBLY	6-1089
40	1	TANK PLASTIC 6.7 OS 22.50" BLK	6-1399
41	1	CABLE TIE 8" LONG WHITE	6-1846
42	1	O-RING 2-348 BUNA	6-0875

PANZITTA SALES & SERVICE
72 George Avenue
Wilkes-Barre, PA 18705
570-822-6720 800-822-6720
www.panzittasales.com